

Hydraulic tractor brush cutter

PTODTDHCY125, PTODTDHCY135

ALNOVA
Instructions and user manual

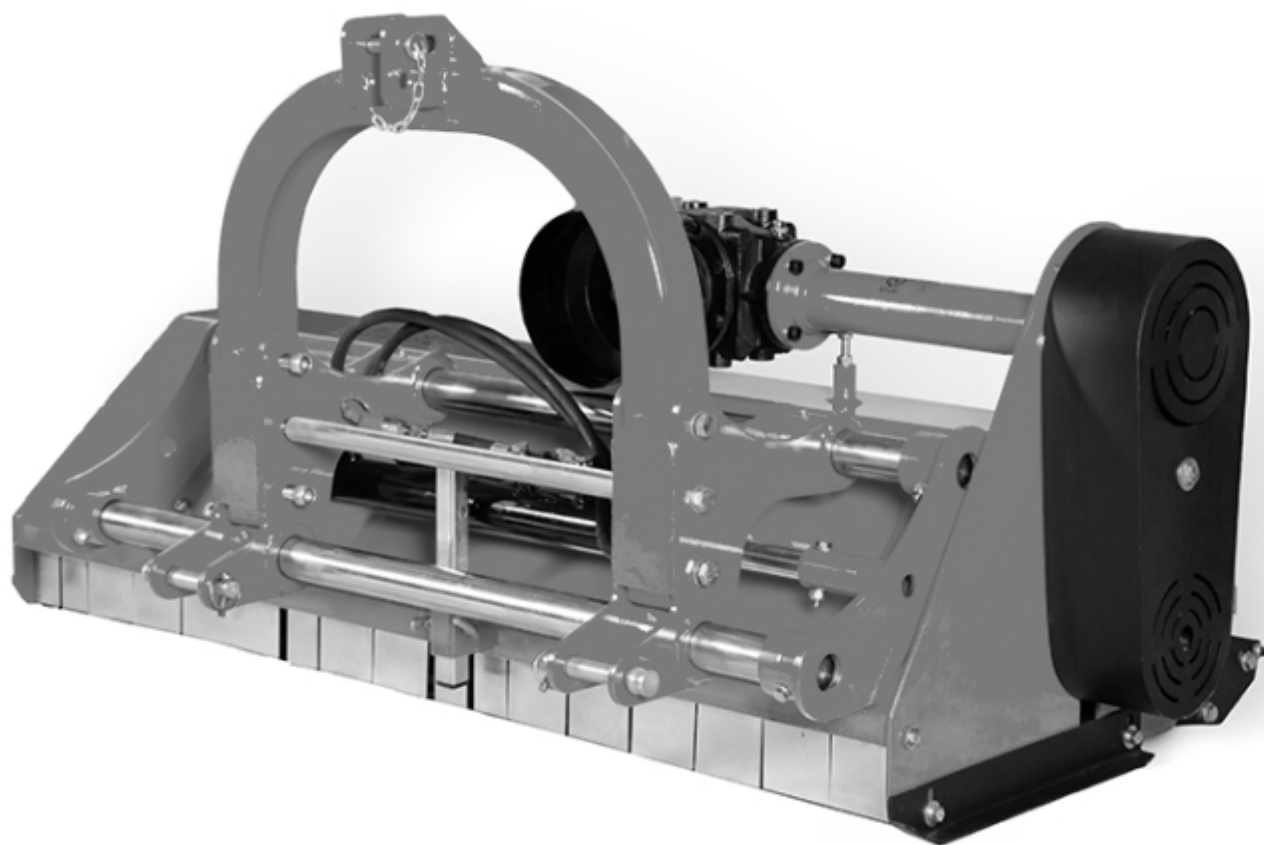

EN

Millasur SLU
Rúa Eduardo Pondal, nº 23 - Pol. Ind. Sigüeiro
15688 - Oroso - A Coruña - 981 696 465 - www.millasur.com





Anova We would like to congratulate you on choosing one of our products and guarantee the assistance and cooperation that has always distinguished our brand over time.

This machine is designed to last for many years and to be of great use if used according to the instructions in the user manual. We therefore recommend that you carefully read this instruction manual and follow all our recommendations.

For more information or questions, you can contact us through our web support at www.anova.es.

INFORMATION ABOUT THIS MANUAL

Pay attention to the information provided in this manual and on the appliance for your safety and the safety of others.

- This manual contains instructions for use and maintenance.
- Take this manual with you when you go to work with the machine.
- The content is correct at the time of printing.
- We reserve the right to make changes at any time without affecting our legal responsibilities.
- This manual is considered an integral part of the product and must remain with it in case of loan or resale.
- Request a new manual from your distributor if it is lost or damaged.

READ THIS MANUAL CAREFULLY BEFORE USING THE MACHINE



To ensure your machine delivers the best results, carefully read the usage and safety guidelines before using it.

OTHER WARNINGS:

Improper use could cause damage to the machine or other objects.

Adapting the machine to new technical requirements could cause differences between the content of this manual and the product purchased.

Read and follow all instructions in this manual. Failure to follow these instructions could result in serious personal injury.

INDEX

1. SAFETY INSTRUCTIONS
2. INSTRUCTIONS FOR USE
3. STORAGE
4. WARRANTY
5. ENVIRONMENT
6. PARTS BREAKDOWN

1. SAFETY INSTRUCTIONS

1.1. Safety instructions

Important





Before operating this product, please read and follow the instructions below. To prevent injury to yourself and others, you should also follow local safety regulations.

Keep these instructions for future reference. This manual contains safety information to inform you about the hazards and risks associated with the product and how to prevent them. It also contains important instructions that must be followed during product setup, operation, and maintenance.

It is important that you read and understand these instructions before attempting to operate this equipment. Make sure you are fully familiar with the controls and the correct use of the product.

Throughout this manual, you will find notices that provide safety instructions and information about hazards that could cause personal injury and/or property damage. These include a warning icon to indicate the likelihood and potential severity of injury.

- Danger/Warning: Indicates a hazard that, if not avoided, could result in serious injury.
- Important/Caution: Indicates a hazard which, if not avoided, could result in minor or moderate injury.
- Note/Notice: Indicates information considered important but not related to hazards.

	Turn off the tractor engine and remove the key before working on the machine.
	Risk of being caught in the transmission. Do not approach the machine and avoid wearing loose clothing that could become entangled in moving parts. Risk of projectiles.
	Stay clear of the machine's operating area. Ensure all guards are in place during use.
	Maximum power take-off speed: 540 rpm MAX.
	Hazard of cutting. Keep clear of the machine's operating area. Ensure all guards are in place during use.

Manufacturer identification label:

CE	
TYPE:	YEAR:
SERIAL No.	WEIGHT(Kg)

It is strictly forbidden to remove the safety devices, safety labels, and manufacturer's identification plate

1.2. Safety standards

To avoid accidents during work, it is necessary to observe the most basic safety rules:

1.2.1. Operator

- The operator must not start the machine if they are not in full physical and mental capacity:
 - Good eyesight and good hearing.
 - Read and study the manual.
 - Be mindful of your safety and the safety of others.
 - Be familiar with the use and maintenance of the machine.
 - It is strictly forbidden to drink alcohol, ingest drugs and other substances that may affect the use of the machine.
- Do not wear loose clothing that could get caught in moving parts.
- Use the appropriate safety equipment:
 - Standardized work gloves
 - Safety footwear
 - Helmet
 - Hearing protection device
 - Protective glasses

1.2.2. Machine

The coupling should only be carried out at the points provided for this purpose, in accordance with safety regulations.

- It is forbidden to use the machine as a means of transporting people, animals or objects.
- The machine must be in perfect working order and maintained with original parts.
- It is strictly forbidden to make modifications to the machine without the manufacturer's authorization.

1.2.3. Utilization

- Caution is required during coupling the machine to the tractor and during its uncoupling.
- Maintenance, cleaning and adjustments should only be performed with the tractor engine off and the ignition key removed.
- Make sure there is no one in the machine's operating area.

Note: We decline all responsibility for damages of a natural nature caused by failure to comply with safety and usage rules.

1.3. Residual risks

▲ Important

Even if it complies with the relevant product safety regulations, residual risks may exist given the characteristics of the equipment and the work for which it has been designed.

Residual risks can be minimized by following safety instructions.

- You will reduce the risk of personal injury and damage to equipment if you follow these instructions and are careful.
- Failure to comply with these safety instructions may result in injury to the operator or damage to property.
- Lack of care, improper use, or failure to comply with safety regulations can result in injuries to the hands and fingers when the wedge is in motion.

Note: Even if you take preventive measures, there may be residual, non-obvious risks.

2. INSTRUCTIONS FOR USE

2.1. Before use

Before starting work, check and adjust:

- 1) The tension of the V-belts
- 2) The gear oil level
- 3) The lubrication points

2.1.1. Adjusting the tension of the belts

▲ Attention

To perform this operation, the machine must always be switched off. Remove the belt cover.

- Remove the strap cover
- Loosen screws 1-2.
- Tighten the straps with screw 3-4
- Retighten screws 1-2
- Replace the strap cover.

The recommended working speed is 1.5 km/h, depending on the height and consistency of the grass and the working conditions.

The V-belts are manually adjusted using the adjustment points "B" (diagram below) after loosening the fixing screws. Adjustment is made

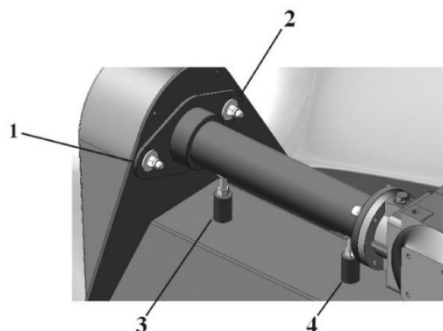

by turning screw B until the correct tension is achieved. Once finished, tighten all loosened screws.

Replace the straps as soon as they are worn or in poor condition.

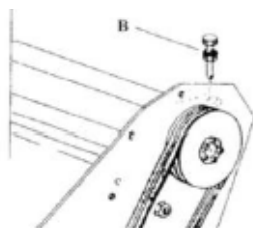

2.1.2. Start

Before using the machine, tighten all bolts, nuts, and screws.

To ensure stability, the machines must be provided with a support when they are in the switched-off position (see diagram below).

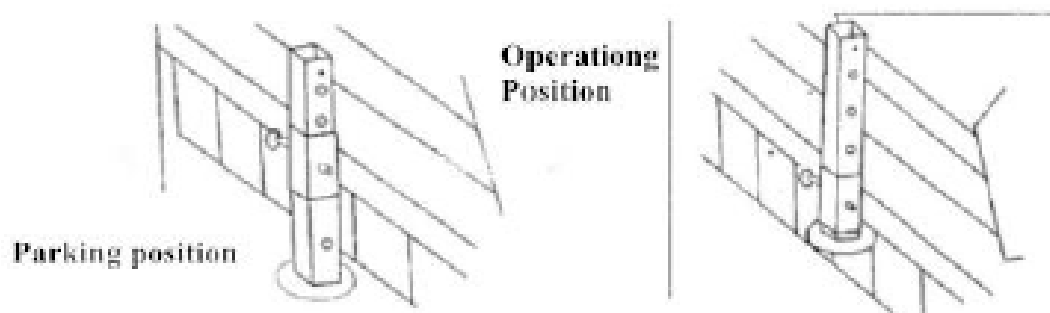

⚠ Attention

It is forbidden to remain in the space between the machine and the tractor when the machine is being changed from the parking position to the working position.

The machine attaches via a 3-point hitch. It can be attached to any tractor equipped with a universal 3-point hitch (N01). Since each tractor's lift bar is a different length, it's necessary to determine the optimal position of the machine relative to the tractor. This position is determined by placing the machine at a distance from the tractor such that the universal joint is tightened to within 5-10 cm of its fully closed position.

Approach the lifting arms and position them between the axles. Insert the pins and secure them with the locking pins. Lock the lifting arms with chains and turnbuckles designed for this purpose to prevent lateral movement of the machine. Attach the universal joint and ensure it is locked to the tractor's PTO shaft and the side of the machine, so that it does not move or shift, regardless of its position. Connect the three-point hitch, making sure the PTO shaft is parallel to the ground. It is crucial that the machine's axle and the tractor's PTO shaft remain parallel at all times.



For the movement, the machine must be lifted from the ground.

Note: Do not use the machine in an enclosed space.

2.1.3. Transmission

▲ Attention

Only use cardan joints that comply with CE regulations and respect the protection measures.

The universal joint should only be installed with the tractor engine switched off and the key removed.

The gasket installation must be perfect and the guard must be in the correct position.



Make sure the chains located on the cardan joint guard are securely fastened to prevent self-rotation.

Keep people away before engaging the power take-off and make sure the tractor's power take-off output is 540 rpm.

Do not approach when the power take-off is in motion.



Before performing any cleaning, maintenance, or lubrication operation, turn off the engine, remove the key, and store it in a safe place.

When the universal joint is no longer attached to the tractor's power take-off, it should be held by its support to prevent damage.

2.1.4. Cutting height

For each specific job, it is recommended to adjust the machine to the task you wish to perform.

To save fuel and energy, and reduce machine wear, adjust the working height correctly.

To adjust the working height, loosen screw N01, remove the screws to the right and left of N02, and adjust the roller height (see diagram below) by placing the attachment in the desired position. The lower hole provides a greater cutting height; replace screw N02 in the selected hole and tighten these four screws N01 and N02.

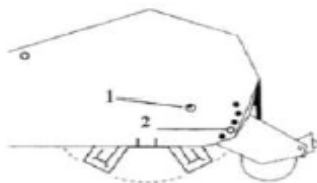

The machine has been manufactured in such a way that the cardan joint rotates at 540 rpm; therefore, it must be equipped with a chain-shaped guard to prevent spontaneous rotation when the cardan joint is in use.

2.1.5. Technical data

	PTODTDHCY125	PTODTDHCY135
HP tractor	25-35 HP	25-35HP
Cutting width	1250 mm	1350 mm
PTO speed	540 rpm	540 rpm
Number of blades	84	84
Type of blades	AND	AND
Dimensions	1396×785×680 mm	1496×785×680 mm
Weight	240 kg	255 kg

2.1.6. Gears

Before starting the machine, check it periodically

Check the oil levels

Check that the intake ventilation grille on the gearbox is not obstructed. If it is, clean it or unblock it with compressed air.

After 50 hours of operation, the oil should be changed; thereafter, every 250 hours and at least once a year.

Proceed as follows: remove the drain screw located underneath

Proceed as follows: remove the drain screw located under the gear to allow the oil to drain out; then replace the plug and refill with gear oil to the indicated level.

Use the same type of oil SAE 90 EP

Do not spill oil or grease on the V-belts; if this happens, clean them off completely to prevent slippage and wear of the V-belts.

▲ Attention

Every 10 hours, check the machine for any damaged, worn, or missing blades, and replace them according to the manufacturer's recommendations to avoid imbalances.

Check and replace the fastener if necessary.

Do not remove the guards that prevent access to dangerous points and protect the machine.

Do not install worn, missing, or damaged blades, as this can cause dangerous imbalances. Check the blades and mounting hardware daily and replace any missing or worn blades with new ones.

To secure the blade, the bushings must be replaced with new ones if they are worn.

Always use original fixing screws.

▲ Attention

If vibrations occur, the machine should be stopped and the blades inspected. If they are broken or damaged, they must be replaced with new blades. If the machine continues to vibrate after this, take it to a specialist workshop for servicing.

2.1.7. Lubrication

Before starting the machine, check that all internal parts are lubricated.

Regarding the universal joint, follow the manufacturer's recommendations.

The hammer mower rotor is equipped with bearings on both sides that must be lubricated; use a hand tool and lubricate frequently in small amounts.

Clean the grease nozzles before each lubrication.

Inject the grease into the bearings slowly. Avoid applying excessive pressure to prevent damage to the bearing fittings.

▲ Attention

For any intervention, repair, cleaning or lubrication, turn off the tractor engine and remove the key; keep it with you.

Use gloves and appropriate tools to replace cutting tools.

Replace worn or broken guards.

Drain the oil within the recommended timeframe.

Don't forget to disconnect the generator cable and battery if you need to perform welding on the machine while it is attached to the tractor.

Use only replacement parts specifically designed for your machine.

Check that all screws and nuts are properly tightened before using it.

3. STORAGE

The machine must be thoroughly cleaned to prevent corrosion.

Do not direct a jet of water towards the bearings if you are cleaning the machine with a high-pressure washer.

Check the accessories, such as the cardan shaft, rollers, and belt; clean them thoroughly, check their condition, and replace them with new ones if necessary.

Lubricate all parts that require it.

Add the rust inhibitor and, if possible, repaint any scratched or damaged parts.

3.1. Start-up after storage

- 1) Check the oil level and top up if needed.
- 2) Check and tighten all screws and nuts.
- 3) Check the machine settings.
- 4) Check the condition of the blade.

4. WARRANTY

If your product suffers any manufacturing defect during the established warranty period, please contact or go directly to your point of sale with the necessary documentation.

Your purchase receipt should be kept as proof of the purchase date. Your tool must be returned to your distributor in acceptable and clean condition, in its original molded case, if applicable, along with your corresponding proof of purchase.

4.1. Warranty period

The legal warranty period for the product begins on the original date of purchase by the first initial buyer and its duration will be that established by the Royal Decree-Law on the protection of consumers and users against situations of social and economic vulnerability of the year corresponding to the time of acquisition of the product.

Some countries do not have limitations on how long an implied warranty lasts or do not allow the exclusion or limitation of consequential or incidental damages, in which case the above limitation and exclusion may not apply to you. This warranty gives you specific legal rights, and you may also have other rights that vary from state to state or country to country.

4.2. Exclusions

This warranty does not cover product damage or performance problems caused by:

- Natural wear and tear from use.
- Misuse, negligence, careless operation, or lack of maintenance.
- Defects caused by improper use, damage caused by handling by personnel not authorized by Anova or use of non-original spare parts.
- Defects in normal wear parts, such as bearings, brushes, cables, plugs or accessories such as drills, drill bits, saw blades, etc.
- Damage or defects resulting from abuse, accidents, or alterations.
- Incorrect use and storage (explicit reference to the fact that the rules described in the operating instructions have not been followed).
- Wear and tear caused by the customer (e.g., broken saw blades, consumed carbon brushes, etc.).
- Wear and secondary damage due to lack of maintenance, repair, lubricants (e.g., overheating damage due to blocked cooling slots, bearing damage as a result of dirt, frost damage, etc.)
- Damage as an obvious result of overuse/overload.
- Damage caused by inappropriate supplies (e.g., incorrect fuel)
- Load-induced breakage of housing components or accessories due to abnormal stress

- Load-induced deformation of the housing components or accessories due to abnormal stress.
- Damage resulting from the operation of supplies that are overfilled or leak due to improper storage, improper cleaning agents, or other damaging chemical components.
- Damage due to improper exposure to extreme temperatures (e.g., frost cracking, thermal deformation of components, etc.)
- Damage from permanent exposure to ultraviolet radiation.
- Damage caused by inadequate maintenance.
- Any damage caused by failure to follow the instructions in the instruction manual
- Any product that has been repaired by an unqualified professional.
- Any product connected to an unsuitable power source (amps, voltage, frequency).
- Any damage caused by external influences (water, chemicals, physical, impacts) or foreign substances.
- Use of unsuitable accessories or parts.
- It does not cover defects in normal wear and tear parts, nor does it cover damage or defects resulting from abuse, accidents or alterations, nor transportation costs.

Furthermore, the warranty is voided if the product has been altered or modified, or if the trademark/serial number of the machine has been defaced or removed.

Routine maintenance, tuning, adjustments, or normal wear and tear are not covered under this warranty.

This manual does not cover all possible situations regarding warranty exclusions; for more information, please contact your nearest Anova distributor.

4.3. In case of incident

The warranty must be correctly completed with all the requested information, and accompanied by the purchase invoice.

Anova reserves the right to refuse any claim where the purchase cannot be verified or where it is clear that the product was not properly maintained (maintenance, clean ventilation slots, lubrication, regularly maintained carbon brushes, cleaning, storage, etc.).

Private use is defined as personal domestic use by an end consumer. Commercial use, on the other hand, means all other uses, including uses for business purposes, income generation, or rental. Once the product has been used for commercial purposes, it will be considered a commercial product thereafter for the purposes of this warranty.

These are our standard warranty terms, but occasionally there may be additional warranty coverage not specified at the time of publication. For more information, please contact your nearest authorized Anova dealer or visit www.millasur.com.

Warranty service is only available through authorized Anova distributors. You can find your nearest distributor on our distributor map at www.anova.es.

5. ENVIRONMENT



It is essential to ensure that products and their components are disposed of responsibly to protect the environment. Below, you will find general guidelines for the proper disposal of various materials used in your machine.

Dispose of your machine in an environmentally friendly way. We shouldn't throw machines away with the regular household waste. Their plastic and metal components can be sorted according to their type and recycled.

When disposing of machinery or metal products, it's important to remember that their metal components, such as iron, steel, or aluminum, must be properly recycled at metal recycling facilities. This will contribute to their potential reuse in the manufacture of new products.

Oils and Fuels

Used oils and fuels, among other things, must be recycled properly. Do not pour these liquids down drains, into soil, rivers, lakes, or seas, as they can cause serious environmental damage. Take them to a recycling center or specialized collection point. This process helps prevent water and soil contamination and allows for the safe reuse of oils, if possible.

Plastics

Plastics should be separated and taken to designated recycling points. Do not throw them away with regular household waste. Plastics can be recycled, helping to reduce waste.

Cardboard

Packaging materials, such as cardboard, are recyclable. Be sure to separate clean, dry cardboard and place it in designated recycling containers or at an official waste collection point. Do not dispose of it with household waste.

Batteries

Batteries and other electronic components from machines must be disposed of at designated collection points to prevent the release of toxic substances into the environment. Do not throw them away with regular trash. Take them to appropriate recycling centers for safe and responsible handling.

By following these guidelines, you contribute to environmental protection and resource conservation. For more information on material disposal and recycling, please contact your local authorities and consult the necessary information.

6. PARTS BREAKDOWN

