



Parts Manual

Mfg. No: 030526-00
1,600 Watt Briggs & Stratton Inverter



Model Components	Page
Alternator & Control Panel (315811alt).....	4
Enclosure (315811enc).....	8
Engine (315811eng).....	12
Torque Specification Chart.....	18

Not For
Reproduction

Alternator & Control Panel (315811alt)

Note: Unless noted otherwise, use the standard torque specifications

Mfg. No: 030526-00

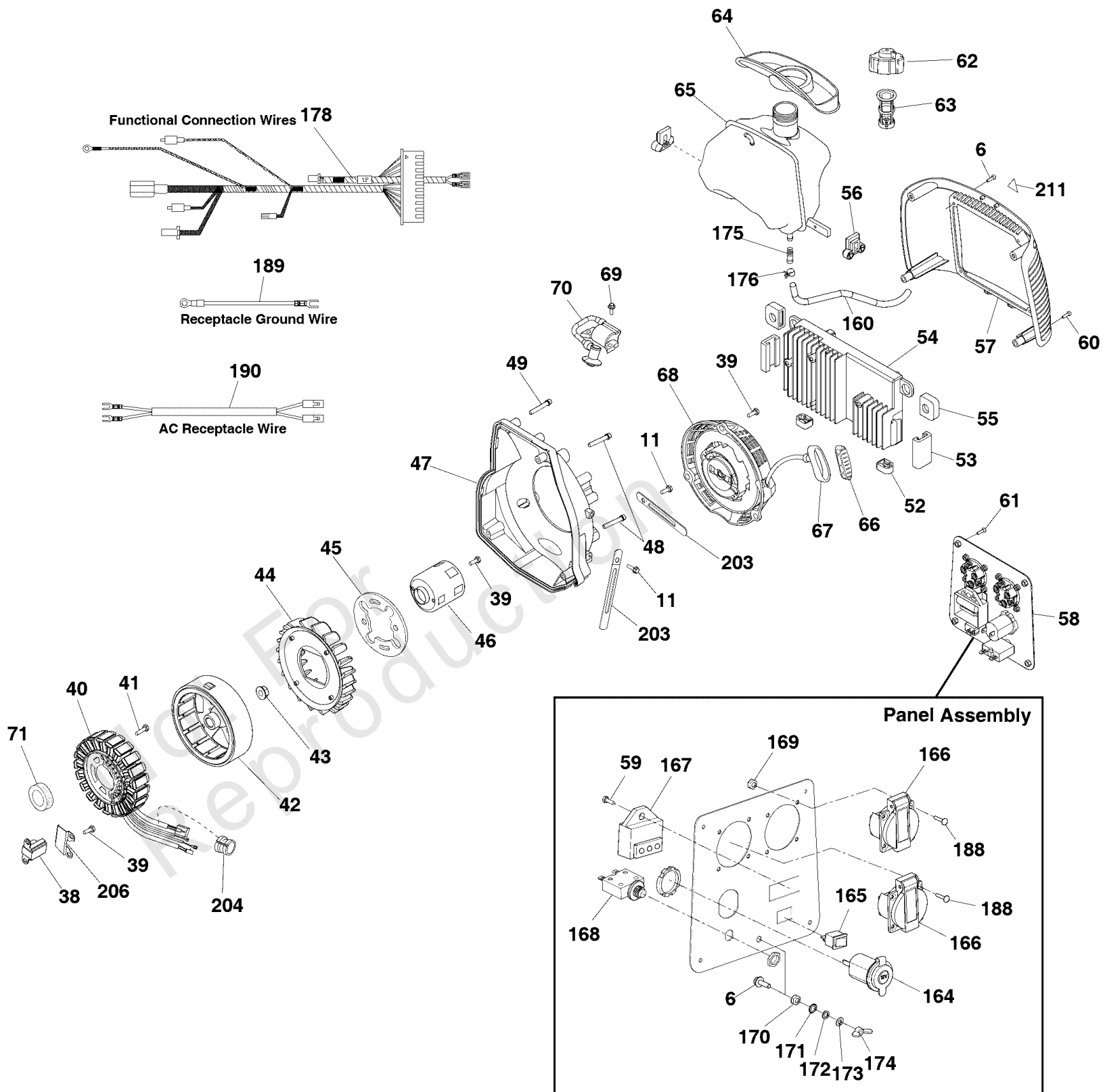

Alternator & Control Panel (315811alt)

REF NO	PART NO	QTY	DESCRIPTION
6	311379GS		SCREW
11	-----		* BOLT
38	311399GS		TRIGGER, Ignition
39	311400GS		SCREW
40	314525GS		STATOR
41	311402GS		SCREW
42	314526GS		ROTOR
43	311404GS		NUT
44	314701GS		FAN
45	-----		* TERMINAL
46	311406GS		CUP, Flywheel
47	-----		* COVER, Fan
48	-----		* BOLT
49	-----		* BOLT
52	-----		* MOUNT, Vibration
53	-----		* MOUNT, Vibration
54	315841GS		INVERTER
55	-----		* MOUNT, Vibration
56	-----		* MOUNT, Vibration
57	314529GS		COVER, Panel
58	315822GS		PANEL, Control
59	-----		* SCREW
60	-----		* SCREW
61	-----		* SCREW
62	311411GS		CAP, Fuel
63	311412GS		FILTER, Filler Neck
64	-----		* PAD, Fuel Tank
65	311413GS		TANK, Fuel
66	311414GS		INSERT, Grip
67	-----		* GRIP
68	706058		STARTER-REWIND
69	-----		* SCREW
70	317436GS		COIL, Ignition
71	-----		* SEAL, Oil
160	317443GS		HOSE, Fuel
164	314531GS		OUTLET, 12VDC
165	311442GS		SWITCH
166	315823GS		OUTLET
167	311443GS		LIGHT, Indicator
168	311444GS		BREAKER, Circuit
169	-----		* NUT
170	-----		* NUT
171	-----		* WASHER
172	-----		* WASHER
173	-----		* WASHER
174	-----		* NUT
175	-----		* FILTER, Fuel Tank
176	-----		* CLAMP

Footnotes:

* Not a serviceable part.

Alternator & Control Panel (315811alt)

Note: Unless noted otherwise, use the standard torque specifications

Mfg. No: 030526-00

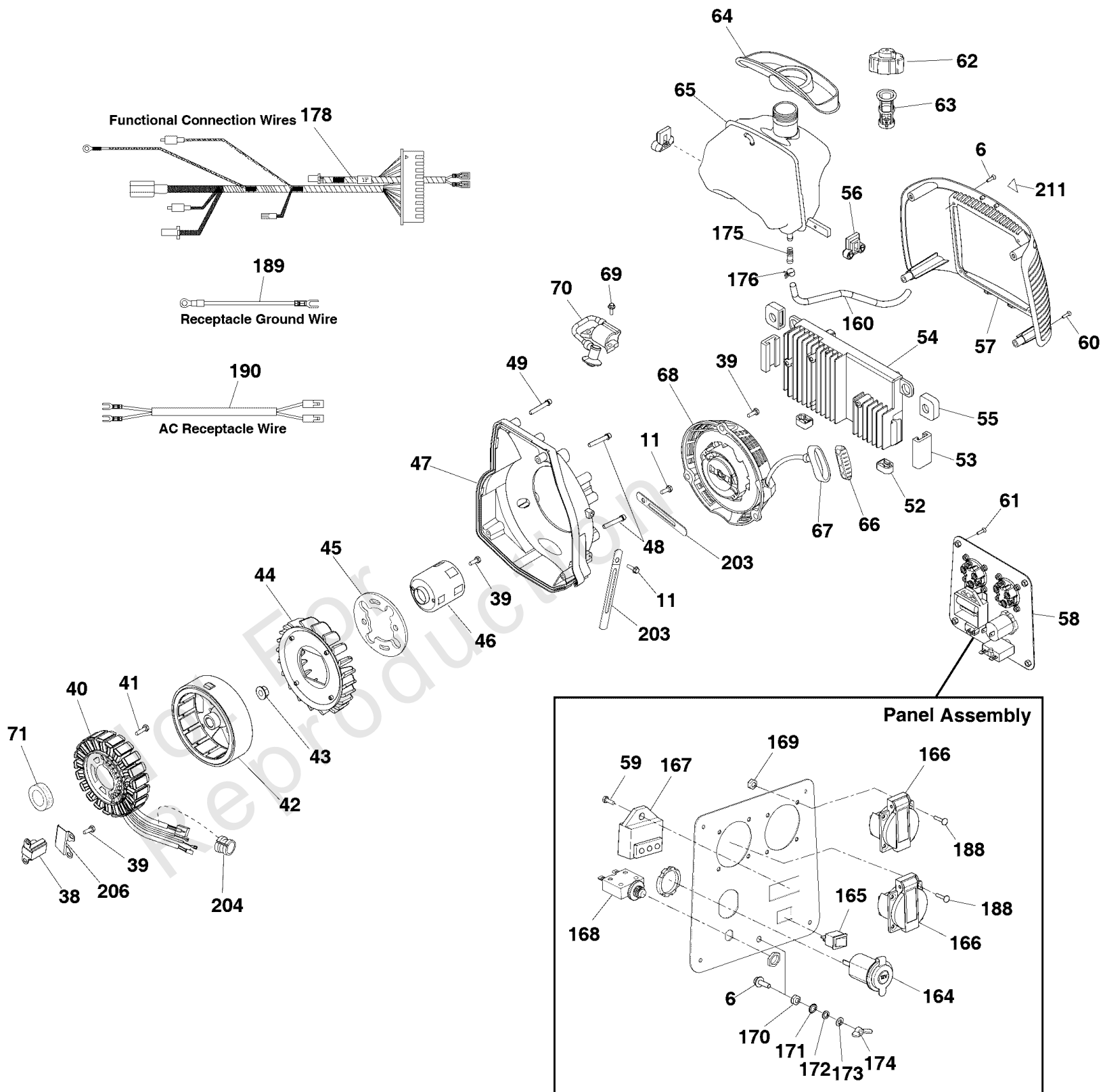

Alternator & Control Panel (315811alt)

REF NO	PART NO	QTY	DESCRIPTION
178	314533GS		HARNESS, Wiring
188	-----		* SCREW
189	315824GS		WIRE
190	315829GS		HARNESS, Wiring
203	707319		* BRACKET
204	-----		* COVER, Rubber
211	315636GS		DECAL
--	187876GS		CABLE, BATTERY CHARGE -(Not Illustrated)
--	100005		OIL-4 CYCLE 30W 18OZ. -(Not Illustrated)
--	703574		KIT, Tool -(Not Illustrated)
--	311559GS		JET, Main, High Altitude, 5000 ft. -(Optional Accessory)

Not For
Reproduction

Footnotes:

* Not a serviceable part.

Enclosure (315811enc)

Note: Unless noted otherwise, use the standard torque specifications

Mfg. No: 030526-00

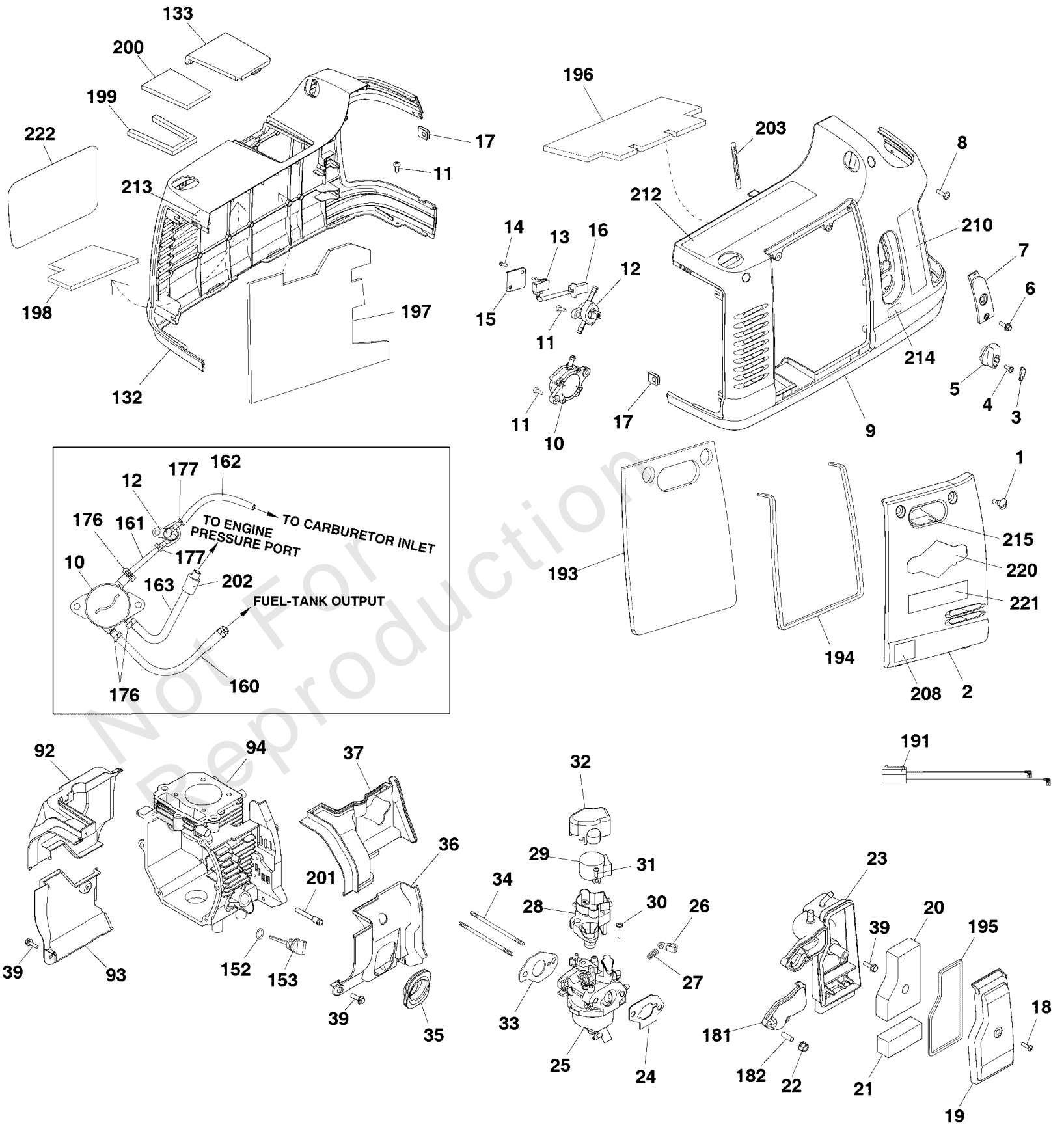

Enclosure (315811enc)

REF NO	PART NO	QTY	DESCRIPTION
1	311375GS		BOLT
2	311376GS		PANEL, Control
3	311377GS		COVER, Knob
4	-----		* BOLT
5	311378GS		KNOB
6	311379GS		SCREW
7	311380GS		PLATE, Trim
8	311381GS		BOLT
9	311382GS		COVER, Side -(Includes Items 210, 212 & 214)
10	706057		PUMP-FUEL
11	-----		* SCREW
12	311384GS		VALVE, Fuel
13	311385GS		SWITCH, ON/OFF
14	-----		* BOLT
15	-----		* COVER, Switch
16	-----		* CONNECTION
17	-----		* NUT
18	311386GS		SCREW
19	311387GS		COVER, Air Cleaner -(Includes Item 195)
20	311388GS		FILTER, A/C Foam
21	311389GS		FILTER, A/C Foam
22	-----		* NUT
23	311390GS		BASE, Air Cleaner
24	311391GS		GASKET, Air Cleaner
25	311392GS		CARBURETOR
26	311393GS		ROD, Throttle
27	-----		* SPRING
28	311394GS		BRACKET
29	311395GS		MOTOR, Stepper
30	-----		* BOLT
31	-----		* BOLT
32	311396GS		COVER
33	311397GS		GASKET
34	311398GS		STUD
35	-----		* SEAL, Rubber
36	-----		* DEFLECTOR
37	-----		* DEFLECTOR
39	311400GS		SCREW
92	-----		* DEFLECTOR
93	-----		* DEFLECTOR
94	-----		CRANKCASE
132	772014		COVER, Side -(Includes Item 197, 198 & 213)
133	311430GS		COVER, Spark Plug
152	311433GS		O-RING
153	311434GS		DIPSTICK
160	317443GS		HOSE, Fuel

Footnotes:

* Not a serviceable part.

Enclosure (315811enc)

Note: Unless noted otherwise, use the standard torque specifications

Mfg. No: 030526-00

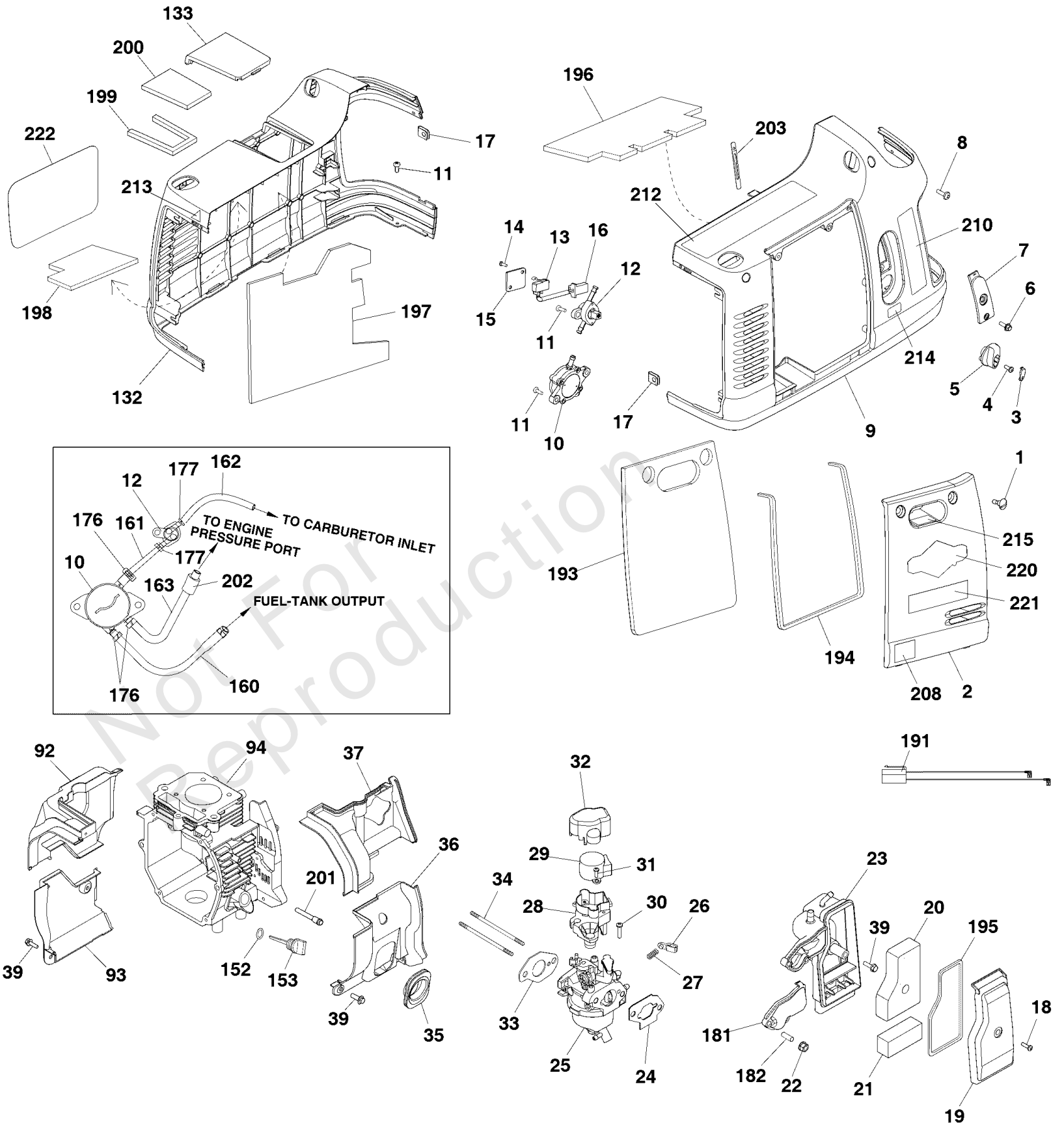

Enclosure (315811enc)

REF NO	PART NO	QTY	DESCRIPTION
161	317444GS		HOSE, Fuel
162	317752GS		HOSE, Fuel
163	311440GS		HOSE, Vacuum
176	-----		* CLAMP
177	-----		* CLAMP
181	312861GS		COVER, Air Cleaner
182	-----		* SLEEVE
191	314479GS		WIRE
193	-----		* FOAM
194	-----		* SEAL
195	-----		* SEAL
196	-----		* FOAM
197	-----		* FOAM
198	-----		* FOAM
199	-----		* SEAL
200	-----		* FOAM
201	-----		* CYLINDER, Breather Tube
202	-----		* TUBE
203	707319		* BRACKET
208	311023GS		DECAL
210	315638GS		DECAL
212	315637GS		DECAL-WARNING
213	315634GS		DECAL
214	311025GS		DECAL
215	315639GS		DECAL
220	707463		DECAL
221	771752		DECAL
222	771751		DECAL

Footnotes:

* Not a serviceable part.

Engine (315811eng)

Note: Unless noted otherwise, use the standard torque specifications

Mfg. No: 030526-00

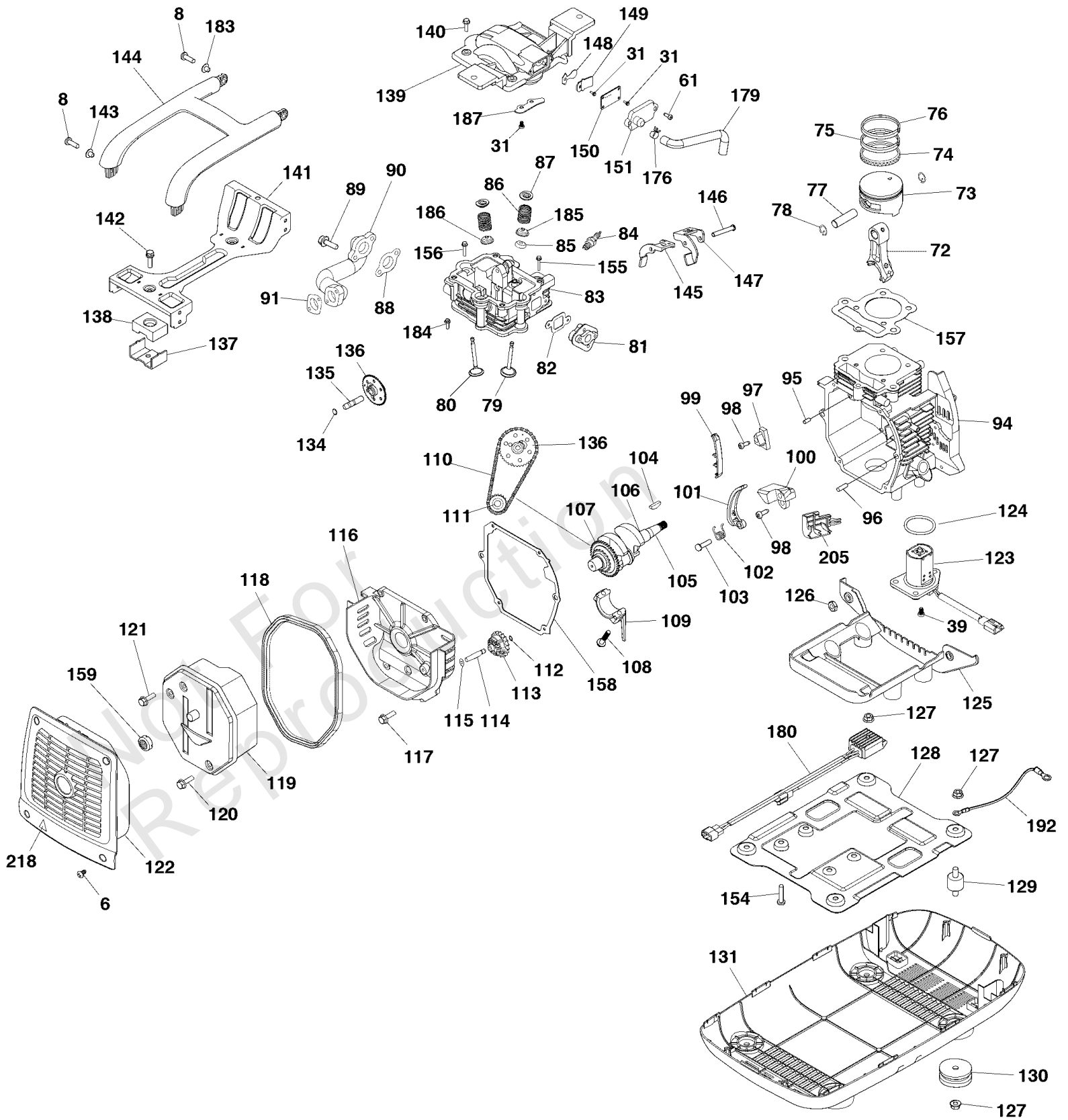

Engine (315811eng)

REF NO	PART NO	QTY	DESCRIPTION
6	311379GS		SCREW
8	311381GS		BOLT
31	-----		* BOLT
39	311400GS		SCREW
61	-----		* SCREW
72	-----		* ROD
73	-----		* PISTON
74	-----		* RING
75	-----		* RING
76	-----		* RING
77	-----		* PIN
78	-----		* RETAINER, Pin
79	-----		* VALVE, Intake
80	-----		* VALVE, Exhaust
81	311417GS		INSULATOR
82	311418GS		GASKET, Intake
83	-----		* CYLINDER HEAD
84	311419GS		SPARK PLUG
85	-----		* SEAL, Valve Oil
86	-----		* SPRING
87	-----		* SEAT, Valve
88	311420GS		GASKET
89	-----		* BOLT
90	-----		* MUFFLER
91	311421GS		GASKET, Exhaust
94	-----		* CRANKCASE
95	-----		* PIN
96	-----		* PIN
97	-----		* BLOCK
98	-----		* SCREW
99	-----		* BRACKET
100	-----		* BRACKET
101	-----		* ARM, Tension
102	-----		* SPRING
103	-----		* PIN
104	-----		* KEY
105	-----		* CRANKSHAFT
106	772065		BEARING
107	-----		* GEAR
108	-----		* BOLT
109	-----		* COVER
110	-----		* CHAIN
111	-----		* WHEEL, Chain
112	-----		* SPRING
113	-----		* WHEEL, Oil
114	-----		* SHAFT
115	-----		* SHIM
116	-----		* COVER, Crankcase

Footnotes:

* Not a serviceable part.

Engine (315811eng)

Note: Unless noted otherwise, use the standard torque specifications

Mfg. No: 030526-00

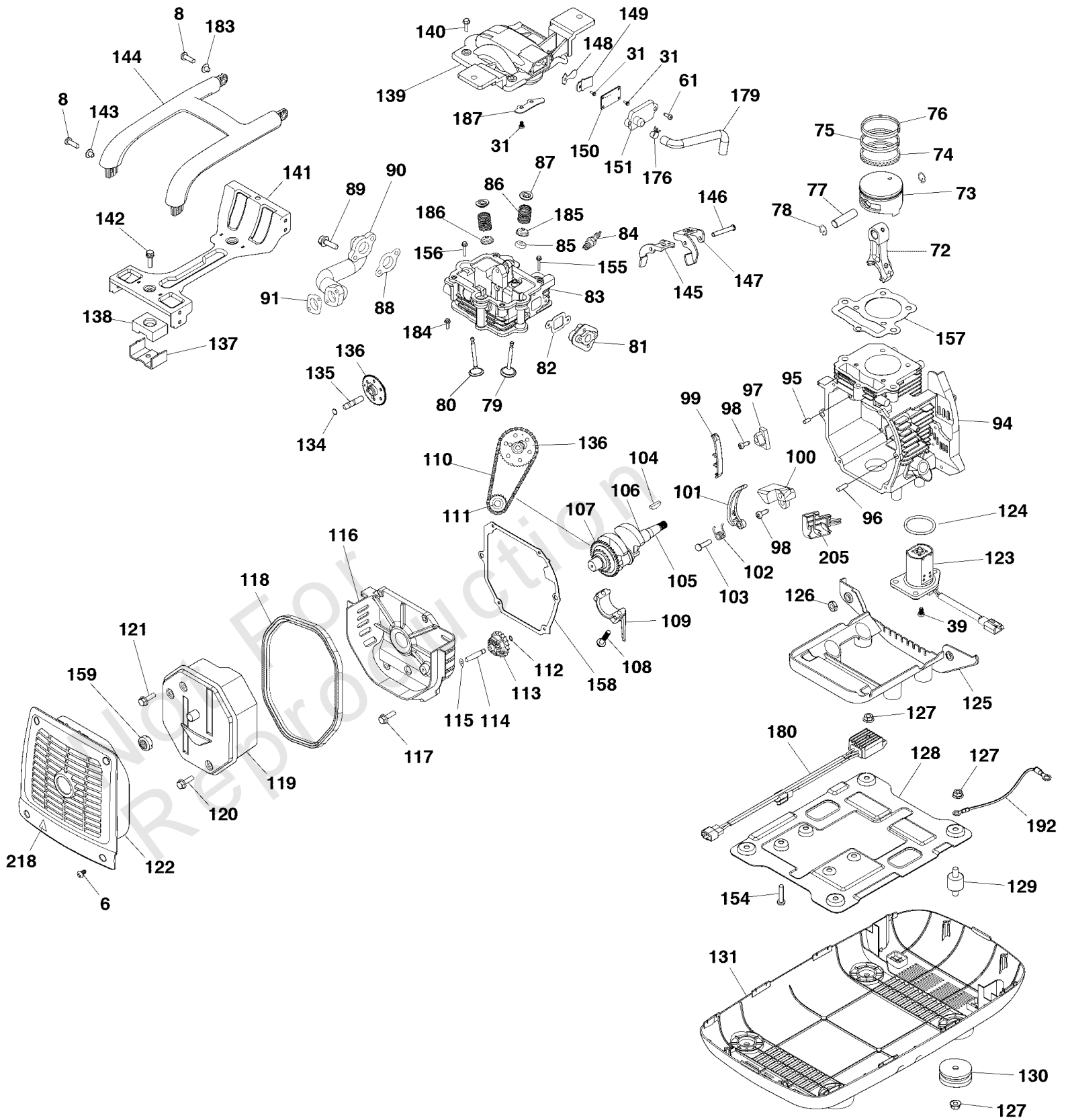

Engine (315811eng)

REF NO	PART NO	QTY	DESCRIPTION
117	-----		* BOLT
118	-----		* BLOCK, Rubber
119	-----		* MUFFLER
120	-----		* BOLT
121	-----		* BOLT
122	704069		GUARD-MUFFLER
123	311423GS		SENSOR, Oil
124	314482GS		O-RING, 33.5 x 2.65
125	-----		* COVER
126	-----		* NUT
127	-----		* NUT
128	311425GS		BASE
129	311426GS		MOUNT, Vibration
130	311427GS		MOUNT, Vibration
131	311428GS		COVER
134	-----		* O-RING
135	-----		* SHAFT
136	-----		* CAM ASSEMBLY
137	-----		* BRACKET
138	-----		* MOUNT, Vibration
139	314786GS		COVER, Cylinder
140	-----		* BOLT
141	-----		* BRACKET
142	-----		* BOLT
143	311431GS		BUSHING
144	311432GS		HANDLE
145	-----		* ARM, Exhaust Valve
146	-----		* PIN
147	-----		* ARM, Intake Valve
148	314747GS		VALVE
149	314748GS		BOARD, Valve
150	-----		* BOARD, Valve
151	-----		* BOARD, Valve
154	-----		* BOLT
155	-----		* BOLT
156	-----		* BOLT
157	-----		* GASKET
158	311435GS		GASKET, Crankcase
159	315584GS		ARRESTOR, Spark
176	-----		* CLAMP
179	311446GS		TUBE, Breather
180	311407GS		REGULATOR, Voltage
183	314478GS		BUSHING
184	-----		* BOLT
185	-----		* SEAT
186	-----		* SEAT
187	-----		* PLATE
192	314483GS		WIRE, Ground

Footnotes:

* Not a serviceable part.

Engine (315811eng)

Note: Unless noted otherwise, use the standard torque specifications

Mfg. No: 030526-00

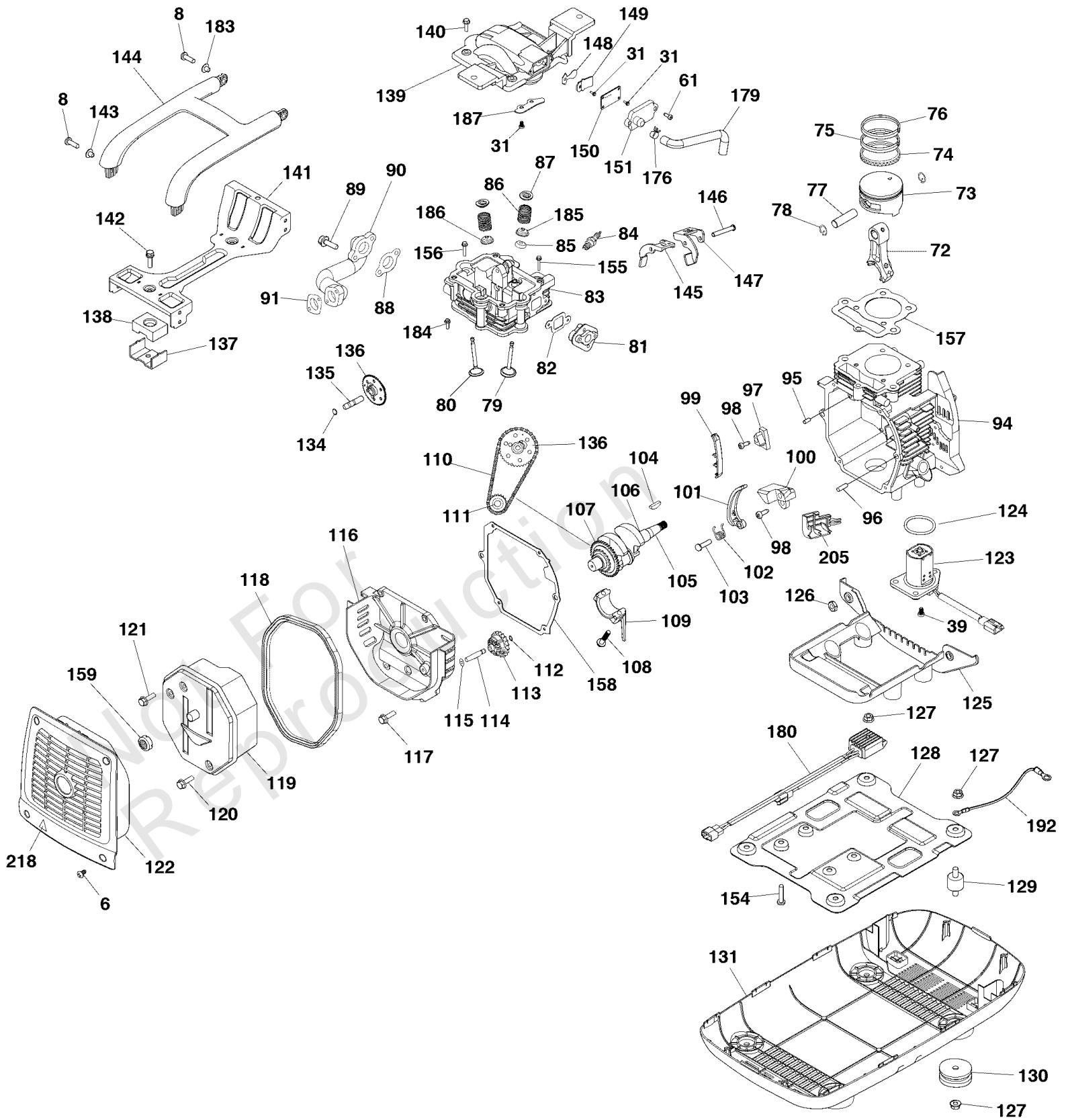

Engine (315811eng)

REF NO	PART NO	QTY	DESCRIPTION
205	-----		* BREATHER
218	315635GS		DECAL

Not For
Reproduction

Footnotes:

* Not a serviceable part.

Hardware Identification & Torque Specifications

Torque Specification Chart								
FOR STANDARD METRIC MACHINE HARDWARE (Tolerance ± 20%)								
Property Class	5.6		8.8		10.9		12.9	
	Class 5.6		Class 8.8		Class 10.9		Class 12.9	
Size Of Hardware	in/lbs	Nm.	in/lbs	Nm.	in/lbs	Nm.	in/lbs	Nm.
	ft/lbs		ft/lbs		ft/lbs		ft/lbs	
M3	5.88	.56	13.44	1.28	19.2	1.80	22.92	2.15
M4	13.44	1.28	30.72	2.90	43.44	4.10	52.56	4.95
M5	26.4	2.50	60.96	5.75	5.97	8.10	7.15	9.7
M6	44.64	4.3	7.3	9.9	10.3	14	12.1	16.5
M7	5.2	7.1	12.1	16.5	16.9	23	19.9	27
M8	7.7	10.5	17.7	24	25	34	29	40
M10	15	21	35	48	50	67	59	81
M12	26	36	61	83	86.2	117	103	140
M14	42	58	101	132	136	185	162	220
M16	64	88	147	200	210	285	250	340
M18	89	121	202	275	287	390	346	470
M20	126	171	290	390	405	550	486	660
M22	169	230	390	530	559	745	656	890
M24	217	295	497	375	708	960	840	1140
M27	320	435	733	995	1032	1400	1239	1680
M30	435	590	995	1350	1401	1900	1681	2280
M33	590	800	1349	1830	1902	2580	2278	3090
M36	759	1030	1740	2360	2441	3310	2935	3980
M39	988	1340	2249	3050	3163	4290	3798	5150

Torque Specification Chart						
FOR STANDARD MACHINE HARDWARE (Tolerance ± 20%)						
Hardware Grade	No Marks		SAE Grade 5		SAE Grade 8	
	SAE Grade 2		SAE Grade 5		SAE Grade 8	
Size Of Hardware	in/lbs	Nm.	in/lbs	Nm.	in/lbs	Nm.
	ft/lbs		ft/lbs		ft/lbs	
8-32	19	2.1	30	3.4	41	4.6
8-36	20	2.3	31	3.5	43	4.9
10-24	27	3.1	43	4.9	60	6.8
10-32	31	3.5	49	5.5	68	7.7
1/4-20	66	7.6	8	10.9	12	16.3
1/4-28	76	8.6	10	13.6	14	19.0
5/16-18	11	15.0	17	23.1	25	34.0
5/16-24	12	16.3	19	25.8	29	34.0
3/8-16	20	27.2	30	40.8	45	61.2
3/8-24	23	31.3	35	47.6	50	68.0
7/16-14	30	40.8	50	68.0	70	95.2
7/16-20	35	47.6	55	74.8	80	108.8
1/2-13	50	68.0	75	102.0	110	149.6
1/2-20	55	74.8	90	122.4	120	163.2
9/16-12	65	88.4	110	149.6	150	204.0
9/16-18	75	102.0	120	163.2	170	231.2
5/8-11	90	122.4	150	204.0	220	299.2
5/8-18	100	136	180	244.8	240	326.4
3/4-10	160	217.6	260	353.6	386	525.0
3/4-16	180	244.8	300	408.0	420	571.2
7/8-9	140	190.4	400	544.0	600	816.0
7/8-14	155	210.8	440	598.4	660	897.6
1-8	220	299.2	580	788.8	900	1,244.0
1-12	240	326.4	640	870.4	1,000	1,360.0

The guides and ruler furnished below are designed to help you select the appropriate hardware.



Nut, M8

Thread Diameter (mm)

Inside Diameter (in) Threads per inch

Nut, 1/2-16



Screw, M8- 1.25 x 25

Thread Diameter (mm) Distance between threads (mm) Body Length (mm)

Body Diameter Threads per inch Body Length (in)

Screw, 1/2- 16 x 2



Standard Hardware Sizing

When a washer or nut is identified as 1/2" (M8), this is the *Nominal size*, meaning the *inside diameter* is 1/2 inch (8mm metric thread diameter); if a second number is present it represents the *threads per inch* (distance between threads).

When bolt or capscrew is identified as 1/2 - 16 x 2" (M8 - 1.25 x 50), this means the *Nominal size*, or body diameter is 1/2 inch (8mm metric thread diameter), the second number, 16, represents the *threads per inch*, (*distance between threads*). The final number is the body length of the bolt or screw, 2 inches (50mm).

NOTES

- These torque values are to be used for all hardware excluding: locknuts, self-tapping screws, thread forming screws, sheet metal screws and socket head setscrews.
- Recommended seating torque values for locknuts:
 - for prevailing torque locknuts - use 65% of grade 5 torques.
 - for flange whizlock nuts and screws - use 135% of grade 5 torques.
- Unless otherwise noted on assembly drawings, all torque values must meet this specification.

Common Hardware Types

Hex Head Capscrew



Washer



Carriage Bolt



Hex Nut

Wrench & Fastener Size Guide

1/4" Bolt or Nut Wrench—7/16"	5/16" Bolt or Nut Wrench—1/2"	3/8" Bolt or Nut Wrench—9/16"	7/16" Bolt or Nut Wrench (Bolt)—5/8" Wrench (Nut)—11/16"	1/2" Bolt or Nut Wrench—3/4"
M6 Bolt or Nut Wrench—10mm	M8 Bolt or Nut Wrench—13mm	M10 Bolt or Nut Wrench—17mm	M12 Bolt or Nut Wrench—19mm	M14 Bolt or Nut Wrench—22mm

