

Instructions - User Manual

PRESSURE CLEANER

H2200



ALOVA[®]

Milesur, SL.
Rúa Eduardo Pondal, nº 23 - Pol. Ind. Sigüeiro
15688 - Oroso - A Coruña 981 696465 www.millasur.com

EN CE

ANOVA thanks you for choosing one of our products and guarantees the assistance and cooperation that has always distinguished our brand over time.

This machine is designed to last for many years and to be of great use if used in accordance with the instructions contained in the user manual. We therefore recommend that you read this instruction manual carefully and follow all our recommendations.

For more information or doubts, you can contact us through our web supports such as www.anova.es

INFORMATION ABOUT THIS MANUAL

Pay attention to the information provided in this manual and on the product for your safety and that of others.

- This manual contains instructions for use and maintenance.
- Take this manual with you when you go to work with the machine.
- The contents are correct at the time of printing.
- The rights to make changes at any time are reserved without affecting our legal responsibilities.
- This manual is considered an integral part of the product and must remain with it in case of loan or resale.
- Ask your dealer for a new manual in case of loss or damage.

READ THIS MANUAL CAREFULLY BEFORE USING THE MACHINE



To ensure that your machine provides the best results, please read the usage and safety regulations carefully before using it.

OTHER WARNINGS:

Incorrect use could cause damage to the machine or other objects.

The adaptation of the machine to new technical requirements could cause differences between the content of this manual and the purchased product.

Read and follow all instructions in this manual. Failure to follow these instructions could result in personal injury

INDEX CONTENT

- 1. SAFETY RULES AND PRECAUTIONS**
- 2. FIELD OF APPLICATION**
- 3. TECHNICAL DATA**
- 4. OPERATING CHARACTERISTICS OF THE PUMP**
- 5. INSTRUCTIONS FOR USE**
- 6. CHANGE PUMP OIL**
- 7. TROUBLESHOOTING**
- 8. MAINTENANCE**
- 9. STORAGE**
- 10. ENVIRONMENT**
- 11. WARRANTY CONDITIONS**
- 12. EXPLODED**
- 13. CE CERTIFICATE**

1. SAFETY RULES AND PRECAUTIONS

Keep your owner's manual so you can refer to it at any time. This owner's manual is considered a permanent part of the pressure washer and must remain with the product.

Your safety and the safety of others are very important. We have provided important safety precautions in this manual and on the machine. Please read these precautions carefully.

Please read this manual carefully and pay particular attention to these symbols and the instructions that follow:

 **Danger:** Indicates that serious injury or death will result if instructions are not followed

 **Warning:** Indicates a strong possibility of serious injury or death if instructions are not followed.







 **Caution:** Indicates the possibility of minor injury or a result if instructions are not followed.











 **Notice:** Indicates that equipment or property damage may occur if instructions are not followed



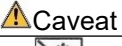



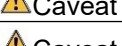
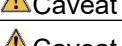
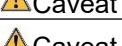
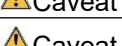
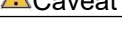



Note: Provides useful information.



If a problem arises or if you have any questions about your high pressure washer, please consult your product dealer.

This book contains important information for the safe operation of this unit. Read and understand all warnings before starting work.

Hazard symbols and meanings					
					
Short circuit	Burst	Electric shock	Injury	Poisoning	Wear protective clothing and glasses

Safety regulations to be taken into account	
	Do not use the product with flammable or toxic liquids, or products that are not compatible with the correct operation of the cleaner.
	Do not use the product within the reach of people unless they are wearing protective clothing and safety glasses.
	Do not use the product if a power cord or important parts of the product are damaged, e.g. Eg safety devices, high pressure hoses, trigger gun.
	Do not direct the water jet towards people or animals, electrical equipment or the machine itself.
	Do not use the product outdoors in case of rain.
	Do not allow children or unprofessionals to use the product.
	Do not touch the plug and/or socket with wet hands.
	Do not use the product if the power cord is damaged.
	Do not use the product if the high pressure hose is damaged.
	Do not squeeze the trigger in the operating position.
	Do not alter the calibration of the safety valve.
	Do not alter the original diameter of the spray tip.
	Do not leave the product unattended.
	Do not move the product by pulling on the power cord.
	All electrical conductors must be protected against jet water
	The product must only be connected to a properly grounded power supply. The use of a safety residual current circuit breaker (RCCB) will provide additional protection for the operator (30mA).

	The high pressure jet can cause loose particles to be propelled at high speed, so wear protective clothing and goggles.
 Caveat	Before carrying out any work on the vacuum cleaner, remove the plug from the outlet.
 Caveat	Before pulling the trigger, grip the squirt gun firmly to counter recoil.
 Caveat	Maintenance and/or repair of electrical components must be carried out by qualified personnel.
 Caveat	Release residual pressure before disconnecting the high pressure hose.
 Caveat	Before using the product, check each time that the screws are well tightened and that there are no broken or worn parts.
	Use only detergents that do not corrode the lining materials of the high pressure hose / pump / electrical cable. Do not use bleach, alcohol, gasoline, hydrochloric acid, etc. as a solvent which is easy to burn and erode.
 Danger	The product operates at fluid pressures and velocities high enough to penetrate human and animal flesh, which could result in amputation or other serious injury. Do not treat fluid injection as a simple cut, see a doctor immediately.
 Caution	Use only chemicals designed for pressure washers or mild soaps and chemicals compatible with aluminum and brass pressure washer parts.
 Caution	The machine uses normal temperature and the temperature for the inlet water should not exceed 50°C. The machine cannot be used with the temperature of 0°C or below 0°C.

Symbol	Indicator
	This manual should be read before starting the installation of the unit.
	High pressure water jets are potentially dangerous if used incorrectly. In particular, do not direct the water jet towards people or animals, electrical equipment or the machine itself.

2. FIELD OF APPLICATION

- Maintain and wash diversified vehicles, project machinery, architectural machinery and agricultural machinery.
- Maintain and wash military vehicles, tanks, boats, planes and other military machinery.
- Wash and disinfect port containers located by divers.
- Washing sanitation recovery and disinfection in livestock.
- Daily washing of the glass of the building and the exterior wall.
- Wash and disinfect the environment of the town square, the street, hospitals, hotels, restaurants and patios.
- Wash and disinfect the sanitary station, clean points and garbage transfer stations.

3. TECHNICAL DATA

Model	H2200
pump model	3WZ-18070BS
Max. Pressure (PSI/bar)	1160/80
Flow (GPM/L/min)	3.38/12.8
RPM	2900
Power	2.2
Gross weight (kg)	28.5
Dimension (cm)	58x42x39.5



1. gun hook
2. hose hook
3. Handlebar
4. adjustable regulator
5. Bomb
6. Chassis
7. Entry
8. Departure
9. Electric motor
10. rubber wheel
11. switch
12. Power cord
13. high pressure hose
14. Spear
15. Gun

4. OPERATING CHARACTERISTICS OF THE PUMP

Please check each part according to the packing list when you open the box, to check whether the parts are complete and in good condition, and keep the attachment and documents in good condition.

1. CHANGE THE OIL INLET PLUG

⚠ Caution: The red cap on the pump is specially designed for transportation; Before using the unit, replace the red plug with the yellow plug or the brass plug in the parts pack.

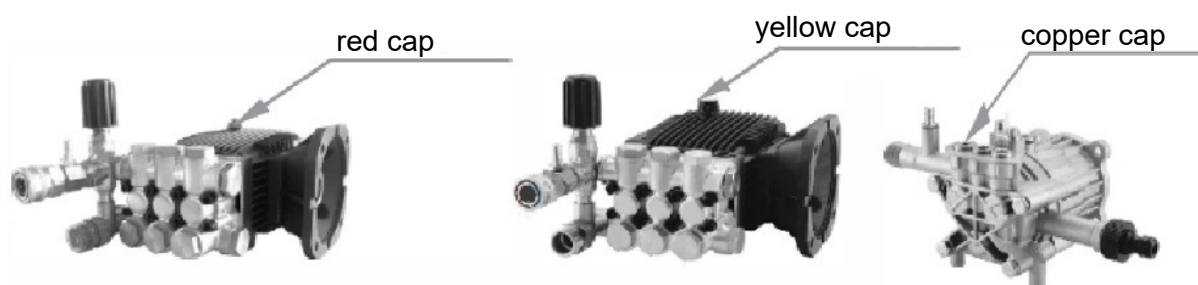

2. PRESSURE REGULATOR





The pressure setting is preset at the factory for optimal pressure and cleaning. If it is necessary

to reduce the pressure, the following methods can be used:

- Move away from the surface to be cleaned. The further away the user is, the lower the pressure on the surface to be cleaned.
Warning: Do not attempt to increase pump pressure, a pressure setting higher than the factory pressure setting may damage the pump.
- Change to the 40° white nozzle. This nozzle provides a less powerful stream of water and a wider spray pattern.
- Adjust the pump pressure regulator. Turn the pressure regulator knob counterclockwise to lower the pressure. Once you have finished using your pressure washer, return the pressure regulator to its original position by turning it clockwise.
- Do not try to turn the pressure regulator knob beyond the built-in stop line, otherwise the pump will be damaged.

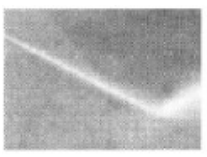
3. NOZZLE TYPE

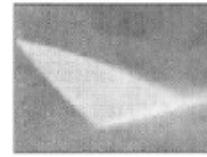
Your unit is equipped with four spray nozzles. Each nozzle is color coded and offers a specific spray pattern for a particular cleaning purpose.

	0°	15°	25°	40°	chemical nozzle
Applications					
Caution: The high pressure spray from your unit can damage surfaces such as wood, glass, automotive paint, automotive trim and trim, and delicate objects such as flowers and shrubs. Before spraying, check the item to be cleaned to make sure it is strong enough to resist damage from the force of the spray.					

4. CHANGE OF NOZZLES

Caution: Do not attempt to change nozzles while unit is running. Shut off motor or gun before changing tip.

- Pull back on the quick fix and insert the nozzle.
- Release the quick-lock nipple and twist to make sure it is secure in the quick-lock socket.
Warning: Risk of injury. Make sure the nozzle is fully inserted into the quick-lock socket before triggering the gun.



5. CLEANING NOZZLES

If the nozzle is clogged with materials such as dirt, excessive pressure can develop. If the nozzle becomes partially clogged or restricted, the pump pressure will vibrate. Clean the nozzle immediately using the supplied nozzle kit and following the instructions:

- Turn unit off and shut off water supply.
- Squeeze gun trigger to relieve water pressure.
- Disconnect the lance from the gun.
- Remove the nozzle from the lance. Remove any clogs with the provided nozzle cleaning tool and rinse with clean water.
- Direct the water supply at the end of the spray wand to remove particles for 30 seconds.



- Reassemble the nozzle to the lance, making sure the attachment is secure.
- Reconnect the lance to the gun and turn on the water supply.
- Turn unit on and place lance on high pressure setting to test.

HOW TO USE CHEMICALS OR DETERGENTS

Warning: Application of chemicals or detergents in a low pressure state.

Caution: Use only chemicals or detergents designed for pressure washing or mild soaps.

To apply chemicals or detergents:

- The unit can suck detergents and other chemicals from a separate tank.
- Put the chemical or detergents in the separate tank.
Caution: Chemicals or detergents too viscous to be sucked up. Add the appropriate water.
- Select the chemical nozzle (black). Now you are ready to enjoy your work.

After using chemicals

- Put the clean water into the separate tank and draw it through the chemical injection system to thoroughly flush the system. If chemicals leak into the pump, the pump may be damaged.
- Pumps darkened by chemicals will not be covered under warranty.

Warning: Chemicals or detergents will not siphon when the lance is on the high pressure setting.

5. INSTRUCTIONS FOR USE

1. CHECK BEFORE OPERATION

- Check if all the nuts and bolts are tight enough and check if the power supply and water can reach the flow rate demand of the machine.
- Checking the water filter: It is important to check the water filter before using the machine.

Caution: A well cleaned filter means good performance and long life for your machine.

- Connection to water supply: Connect the water supply to the inlet port using a reinforced hose.

Caution: The machine does not have a flow switch, the water source must provide 15L per minute.

The inlet water temperature must not exceed 50°C

- Attach wand to gun: tighten securely.
- High pressure hose connection: insert the quick connect plug of the high pressure hose into the water outlet, and the other side should be tightened with the trigger of the gun.
- Connection to the electrical supply:
 - Make sure that the mains voltage is the same as that shown on the identification label of the machine.
 - Warning: Make sure that the plug complies with local regulations and that it is provided with an earth connection.
 - Warning: The outlet must be protected by a residual circuit breaker with a sensitivity of less than 30mA.
 - Do not connect other products to the same outlet.
 - Caution: Insert the plug after checking the switch of the machine in the OFF position.

2. MACHINE STARTUP

- Supply the water, then open the gun trigger.
- Turn on the unit.
- Warning: In case of power failure during operation, please turn off the unit for safety reasons.
- Hold the gun in the open position for a few seconds to drain the air from the hose.
- At this point set the machine to your pressure requirements and you are ready to enjoy your work.
- During washing, it is better not to exceed the working pressure, for any special demands,

you can also adjust the pressure as high as the maximum pressure, but the pressure adjustment range should be under the spraying situation.

- During washing, the spray head should not be far from the dirty surface.
Warning: Do not use the machine when there are people and/or within reach of the jet.
- Stop the gun after finishing flushing, and then turn off the motor (no more than 2 minutes), because the discharge valve is still moving after the gun is stopped, the water will flow in circles in the pump, which will cause the water to get hot and damage the seal ring or other accessories if it spends a long time.
- During operation, it is normal for there to be a little water leakage from the pump, which will not affect the use of the machine.
- Safety valve: The safety valve also functions as a pressure relief valve. When the gun trigger is released, the safety valve opens and water recirculates through the pump inlet.

3. STOP THE MACHINE

- When you finish washing, turn off the unit.
- Hold the gun in the open position for a few seconds to drain the water from the hose.

6. CHANGE PUMP OIL

- The oil level should be checked periodically.
- The most important thing is that the oil should be changed after the first 50 hours of work and successively every 100 hours.
- In any case, we suggest changing the oil at least once a year.

Oil type: SAE15W40 or new SAE30.

Oil capacity (ml): 470±5

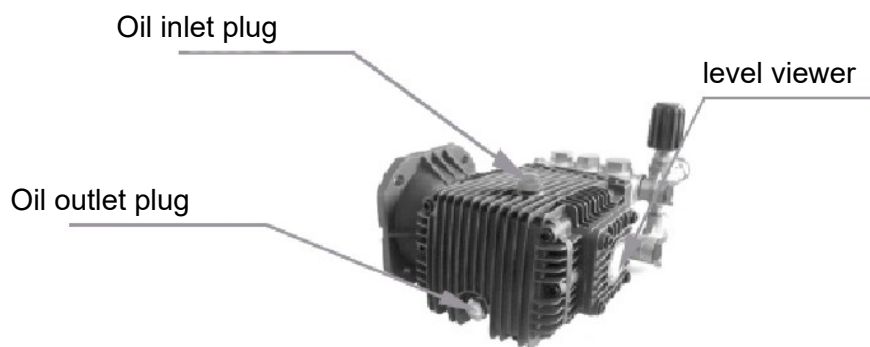

1. How to change the pump oil:

To completely release the used oil from the pump through the oil outlet plug, reinstall the oil outlet plug and let the clean kerosene into the crankcase, the kerosene level should be slightly above the center line of the oil mirror.

Then run the unit without charging for about 10-15 seconds, stop and release all the kerosene. Then apply new SAE15W40 or SAE30 oil. The oil level should be slightly above the red mark on the oil mirror.

7. TROUBLESHOOTING

Problem	Possible cause	Solution
The pump works, but the pressure does not reach the nominal values	pump sucking air	Check that hoses and fittings are airtight
	Worn or dirty valves	Check, clean or replace
	Worn discharge valve packing	check and replace
	Wrong or worn nozzle	check and replace
	Worn piston packing	check and replace
	dirty filter	check and clean
fluctuating pressure	Worn, dirty or stuck valves	Check, clean or replace
	pump sucking air	Check that hoses and accessories are tight.
	Worn piston packing	check and replace
	dirty filter	check and clean
Pressure drops after a period of normal use	worn nozzle	check and replace
	Worn, dirty or stuck valves	Check, clean or replace
	Worn discharge valve packing	Check, clean or replace
	Worn piston packing	check and replace
	dirty filter	check and clean
loud pump	pump sucking air	Check that hoses and accessories are tight.
	Worn, dirty or stuck valves	Check, clean or replace
	worn bearings	Check and replace if necessary
	Hot water	reduce the temperature
	dirty filter	check and clean
water pressure in oil	High humidity in the air	Check and change oil twice as often
	Worn piston packing and oil seal	check and replace
Water leaking from under the pump	piston packing	check and replace
	Worn retainer or piston guide toe o-ring	check and replace
oil drip	Worn oil seal	check and replace
Engine won't start when turned on	The plug is not well connected or lack of power	Check the plug, cable and switch
When I turn on the unit, the motor buzzes but does not work	The voltage of the converged network is insufficient, lower than the minimum required	Check that the mains power supply is adequate
	Convergence pump is stuck or frozen Incorrect extension cord	Follow the precautions in the manual
engine stops	Thermal overload tripped due to overheating	Check that the mains voltage corresponds to the specifications: wait a few minutes before turning the unit on again

8. MAINTENANCE

If the machine is not going to be used for a long time, you need to drain the water from the machine, the way to do this is to disconnect the water inlet hose, run the machine without water supply for about half a minute, and open the gun to drain the remaining water inside the machine.

- The user should frequently clean the filter to prevent the pressure from being insufficient

due to the clogging of the strainer.

- If the electrical cable is damaged, only professionals are authorized to change it.
- Precautions in the case of storage and / or freezing:
 - If the unit is going to be stored in a place where there is a risk of freezing, or if it is going to remain unused for more than three months, we recommend putting some antifreeze in the pump (a normal antifreeze like the one used in your vehicle is sufficient).). In any case, to avoid any risk, we suggest that you place the unit in a warm room for a few minutes before using it.
 - Prolonged periods of disuse can lead to the formation of lime deposits. Working through the hole in the rear, pry the driver off the motor several times with a screwdriver. Then remove the screwdriver and continue with the reset operations.

9. STORAGE

- Store idle power tools in a place that is inaccessible to children and secure in a way that will not endanger anyone.
- The machine out of use must be stored clean, on a flat surface.
- Store the machine in a place where the temperature range is not lower than 0°C and not higher than 45°C.
- Unplug the plug from the power source before storing this machine, completely drain the water from the machine's internal circuits, clean all parts, and store the machine in a safe and dry place.
- You must also drain the water from the hose, gun and lances.
- Clean the detergent tank before storing the machine.
- Before storing the machine, always respect the points in the maintenance chapter.

10. ENVIRONMENT



Please dispose of your product in an ecological way. We must not dispose of machines together with household waste. Its plastic and metal components can be sorted according to their nature and recycled. The materials used to pack this machine are recyclable. Please do not dispose of the packaging in household waste. Please dispose of these packages at an official waste collection point.

11. WARRANTY CONDITIONS

WARRANTY PERIOD

The warranty period under the terms described below is 2 years from the date of purchase, in parts and labor, against manufacturing and material defects.

EXCLUSIONS

The guarantee does not cover in any case:

- Natural wear and tear.
- Misuse, negligence, careless operation or lack of maintenance.
- Defects caused by incorrect use, damage caused due to manipulations carried out by personnel not authorized by Anova or use of non-original spare parts.

APP

- The guarantee ensures service coverage in all applicable cases, although the machine must be accompanied by its respective purchase invoice and be managed through an authorized Anova center.



ATTENTION!

TO ENSURE MAXIMUM OPERATION AND SAFETY, READ THE INSTRUCTION BOOK CAREFULLY BEFORE USE.

12. EXPLODED

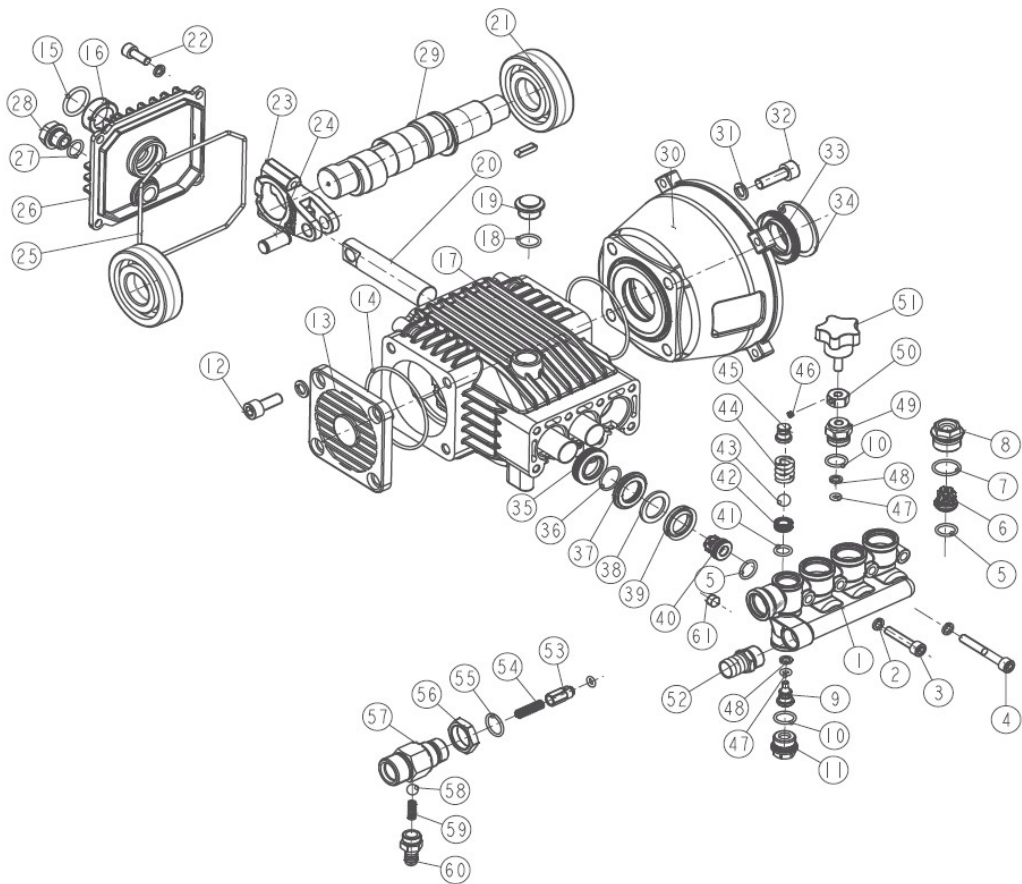
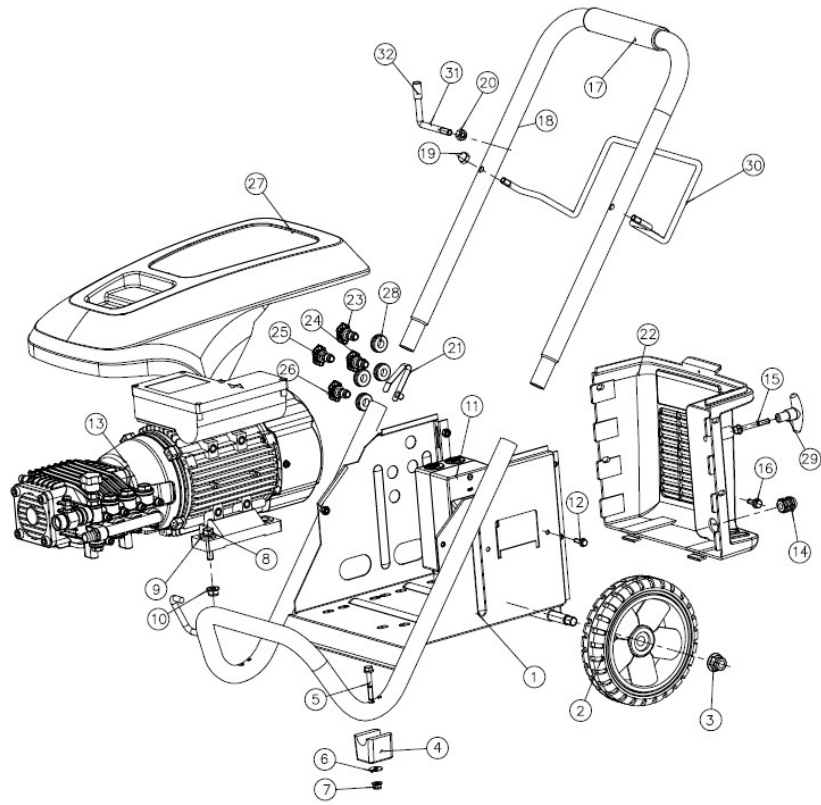

13. CE CERTIFICATE

DECLARATION OF CONFORMITY (CE)

DISTRIBUTION COMPANY

MILLASUR, SL
RUA EDUARDO PONDAL, Nº 23 PISIGÜEIRO
15688 OROSO - A CORUÑA
SPAIN



ALNOVA

EC DECLARATION OF CONFORMITY

In compliance with the different CE directives, it is hereby confirmed that, due to its design and construction, and according to the CE mark printed by the manufacturer on it, the machine identified in this document complies with the relevant and fundamental health and safety requirements. of the aforementioned EC directives. This declaration validates the product to display the CE symbol.

In the event that the machine is modified and this modification is not approved by the manufacturer and communicated to the distributor, this declaration will lose its value and validity.

Name of the machine: PRESSURE CLEANER

Model: H2200

Recognized and approved standard to which it conforms:

Directive 2006/42/EC 2014/30/EU

Tested according to regulations:

EN 60335-1:2012+A11

EN 60335-2-79:2012

EN 62233:2008

Test reports:

14717780 001 50106846 001

Company seal

MILLASUR, S.L.U.

Rúa Eduardo Pondal,23 · Pol.EMP. Sigüeiro
15688-Oroso-A Coruña

Tel.(+34) 981 69 64 65 - Fax (+34) 981 69 08 61

e-mail: millasur@millasur.com

CIF: B-15 749 922

ALNOVA

08/05/2026