

EMTOP

说明书材质要求： A5 80g双胶纸；	说明书成品尺寸：148x210mm
■ Black（单色印刷）	
折叠方式：骑马钉	备注：
特别注意：此页内容不印刷	

更改记录	1. 增加ECSW1853-3货号 2. 内容第一页增加 Original Instructions 3. 说明书背面增加出运标记				
	1222.E05	2022.12.01	LZH		
	版本号	日期	设计师		

EMTOP

CIRCULAR SAW

1600W

INDUSTRIAL

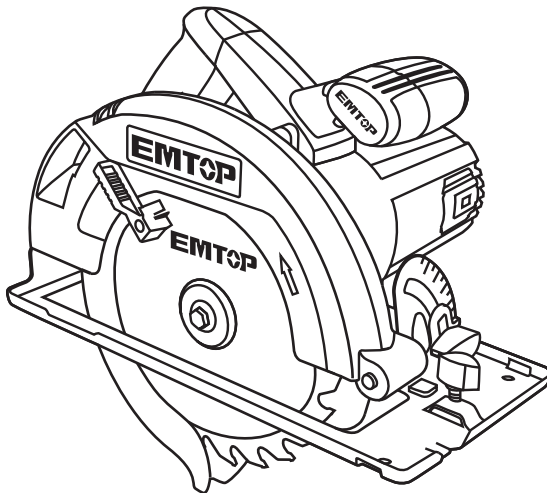

ECSW1853,ULCSW1853,ECSW1853-3,ECSW1853-6
ECSW1853-8,ECSW1853S,ECSW18532

EN Circular Saw







ES Sierra Circular



www.emtop.com

Original Instructions

The symbols in instruction manual and the label on the tool

	Double insulated for additional protection.
	Read the instruction manual before using.
	CE conformity.
	Wear safety glasses, hearing protection and dust mask.
	Waste electrical products should not be disposed of with household waste. Please recycle where facilities exist. Check with your Local Authority or retailer for recycling advice.
	Safety alert. Please only use the accessories supported by the manufacturer.

GENERAL POWER TOOL SAFETY WARNINGS



WARNING Read all safety warnings, instructions, illustrations and specifications provided with this power tool. *Failure to follow all instructions listed below may result in electric shock, fire and/or serious injury.*

Save all warnings and instructions for future reference.

The term "power tool" in the warnings refers to your mains-operated (corded) power tool or battery-operated (cordless) power tool.

1) Work area safety

- a) **Keep work area clean and well lit.** *Cluttered or dark areas invite accidents.*
- b) **Do not operate power tools in explosive atmospheres, such as in the presence of flammable liquids, gases or dust.** *Power tools create sparks which may ignite the dust or fumes.*
- c) **Keep children and bystanders away while operating a power tool.** *Distractions can cause you to lose control.*

2) Electrical safety

- a) **Power tool plugs must match the outlet. Never modify the plug in any way. Do not use any adapter plugs with earthed (grounded) power tools.** *Unmodified plugs and matching outlets will reduce risk of electric shock.*
- b) **Avoid body contact with earthed or grounded surfaces, such as pipes, radiators, ranges and refrigerators.** *There is an increased risk of electric shock if your body is earthed or grounded.*
- c) **Do not expose power tools to rain or wet conditions.** *Water entering a power tool will increase the risk of electric shock.*
- d) **Do not abuse the cord. Never use the cord for carrying, pulling or unplugging the power tool. Keep cord away from heat, oil, sharp edges or moving parts.** *Damaged or entangled cords increase the risk of electric shock.*
- e) **When operating a power tool outdoors, use an extension cord**

suitable for outdoor use. *Use of a cord suitable for outdoor use reduces the risk of electric shock.*

f) If operating a power tool in a damp location is unavoidable, use a residual current device (RCD) protected supply. *Use of an RCD reduces the risk of electric shock.*

3) Personal safety

a) Stay alert, watch what you are doing and use common sense when operating a power tool. Do not use a power tool while you are tired or under the influence of drugs, alcohol or medication. *A moment of inattention while operating power tools may result in serious personal injury.*

b) Use personal protective equipment. Always wear eye protection. *Protective equipment such as a dust mask, non-skid safety shoes, hard hat or hearing protection used for appropriate conditions will reduce personal injuries.*

c) Prevent unintentional starting. Ensure the switch is in the off-position before connecting to power source and/or battery pack, picking up or carrying the tool. *Carrying power tools with your finger on the switch or energising power tools that have the switch on invites accidents.*

d) Remove any adjusting key or wrench before turning the power tool on. *A wrench or a key left attached to a rotating part of the power tool may result in personal injury.*

e) Do not overreach. Keep proper footing and balance at all times. *This enables better control of the power tool in unexpected situations.*

f) Dress properly. Do not wear loose clothing or jewellery. Keep your hair and clothing away from moving parts. *Loose clothes, jewellery or long hair can be caught in moving parts.*

g) If devices are provided for the connection of dust extraction and collection facilities, ensure these are connected and properly used. *Use of dust collection can reduce dust-related hazards.*

h) Do not let familiarity gained from frequent use of tools allow you to become complacent and ignore tool safety principles. *A careless action can cause severe injury within a fraction of a second.*

4) Power tool use and care

- a) **Do not force the power tool. Use the correct power tool for your application.** *The correct power tool will do the job better and safer at the rate for which it was designed.*
- b) **Do not use the power tool if the switch does not turn it on and off.** *Any power tool that cannot be controlled with the switch is dangerous and must be repaired.*
- c) **Disconnect the plug from the power source and/or remove the battery pack, if detachable, from the power tool before making any adjustments, changing accessories, or storing power tools.** *Such preventive safety measures reduce the risk of starting the power tool accidentally.*
- d) **Store idle power tools out of the reach of children and do not allow persons unfamiliar with the power tool or these instructions to operate the power tool.** *Power tools are dangerous in the hands of untrained users.*
- e) **Maintain power tools and accessories. Check for misalignment or binding of moving parts, breakage of parts and any other condition that may affect the power tool's operation. If damaged, have the power tool repaired before use.** *Many accidents are caused by poorly maintained power tools.*
- f) **Keep cutting tools sharp and clean.** *Properly maintained cutting tools with sharp cutting edges are less likely to bind and are easier to control.*
- g) **Use the power tool, accessories and tool bits etc. in accordance with these instructions, taking into account the working conditions and the work to be performed.** *Use of the power tool for operations different from those intended could result in a hazardous situation.*
- h) **Keep handles and grasping surfaces dry, clean and free from oil and grease.** *Slippery handles and grasping surfaces do not allow for safe handling and control of the tool in unexpected situations.*

5) Service

- a) **Have your power tool serviced by a qualified repair person using only identical replacement parts.**
power tool is maintained.

Additional Safety Warnings

Safety instructions for all saws

Cutting procedures

- a)  **DANGER: Keep hands away from cutting area and the blade. Keep your second hand on auxiliary handle, or motor housing. If both hands are holding the saw, they cannot be cut by the blade.**
- b) **Do not reach underneath the workpiece.** *The guard cannot protect you from the blade below the workpiece.*
- c) **Adjust the cutting depth to the thickness of the workpiece.** *Less than a full tooth of the blade teeth should be visible below the workpiece.*
- d) **Never hold the workpiece in your hands or across your leg while cutting. Secure the workpiece to a stable platform.** *It is important to support the work properly to minimize body exposure, blade binding, or loss of control.*
- e) **Hold the power tool by insulated gripping surfaces, when performing an operation where the cutting tool may contact hidden wiring or its own cord.** *Contact with a "live" wire will also make exposed metal parts of the power tool "live" and could give the operator an electric shock.*
- f) **When ripping, always use a rip fence or straight edge guide.** *This improves the accuracy of cut and reduces the chance of blade binding.*
- g) **Always use blades with correct size and shape (diamond versus round) of arbour holes.** *Blades that do not match the mounting hardware of the saw will run off-centre, causing loss of control.*
- h) **Never use damaged or incorrect blade washers or bolt.** *The blade washers and bolt were specially designed for your saw, for optimum performance and safety of operation.*

- c) **When restarting a saw in the workpiece, centre the saw blade in the kerf so that the saw teeth are not engaged into the material.** *If a saw blade binds, it may walk up or kickback from the workpiece as the saw is restarted.*
- d) **Support large panels to minimise the risk of blade pinching and kickback.** *Large panels tend to sag under their own weight. Supports must be placed under the panel on both sides, near the line of cut and near the edge of the panel.*
- e) **Do not use dull or damaged blades.** *Unsharpened or improperly set blades produce narrow kerf causing excessive friction, blade binding and kickback.*
- f) **Blade depth and bevel adjusting locking levers must be tight and secure before making the cut.** *If blade adjustment shifts while cutting, it may cause binding and kickback.*
- g) **Use extra caution when sawing into existing walls or other blind areas.** *The protruding blade may cut objects that can cause kickback.*

Safety instructions for saws with pendulum guard and saws with tow guard

Lower guard function

- a) **Check the lower guard for proper closing before each use. Do not operate the saw if the lower guard does not move freely and close instantly. Never clamp or tie the lower guard into the open position.** *If the saw is accidentally dropped, the lower guard may be bent. Raise the lower guard with the retracting handle and make sure it moves freely and does not touch the blade or any other part, in all angles and depths of cut.*
- b) **Check the operation of the lower guard spring. If the guard and the spring are not operating properly, they must be serviced before use.** *Lower guard may operate sluggishly due to damaged parts, gummy deposits, or a build-up of debris.*
- c) **The lower guard may be retracted manually only for special cuts such as "plunge cuts" and "compound cuts". Raise the lower guard by the retracting handle and as soon as the blade enters the material, the lower guard must be released. For all other sawing, the lower guard should operate automatically.**
- d) **Always observe that the lower guard is covering the blade before placing the saw down on bench or floor.** *An unprotected, coasting blade will cause the saw to walk backwards, cutting whatever is in its path. Be aware of the time it takes for the blade to stop after switch is released.*

Residual risks

Even when the power tool is used as prescribed it is not possible to eliminate all residual risk factors. The following hazards may arise in connection with the power tool's construction and design:

- a) Health defects resulting from vibration emission if the power tool is being used over longer period of time or not adequately managed and properly maintained.
- b) Injuries and damage to property to due to broken accessories that are suddenly dashed.



Warning! This power tool produces an electromagnetic field during operation. This field may under some circumstances interfere with active or passive medical implants. To reduce the risk of serious or fatal injury, we recommend persons with medical implants to consult their physician and the medical implant manufacturer before operating this power tool.

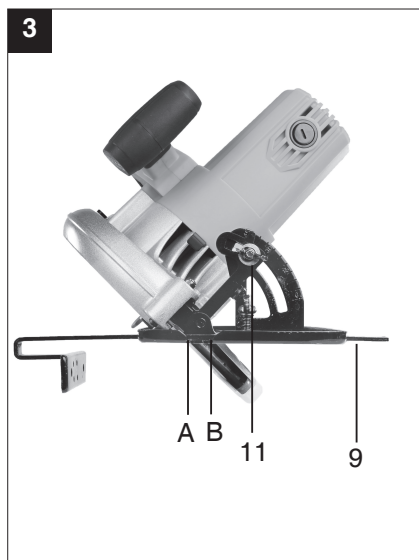
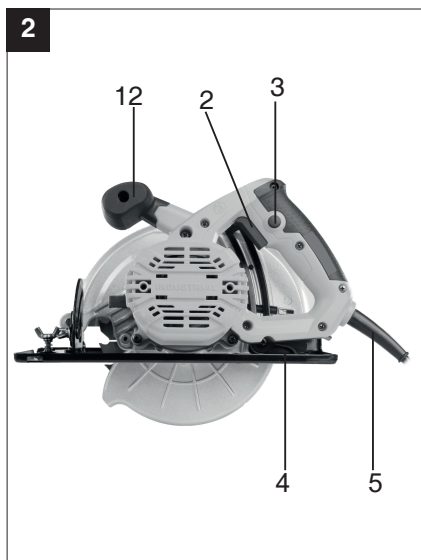
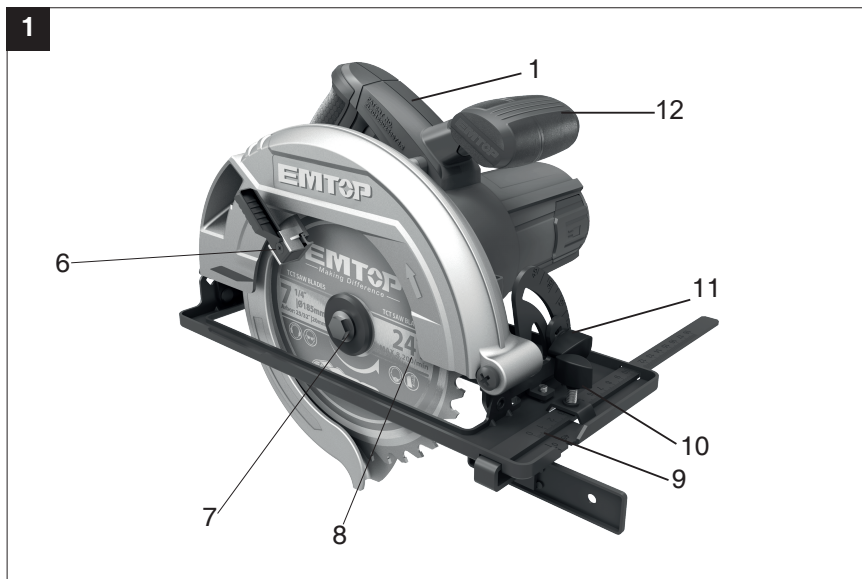

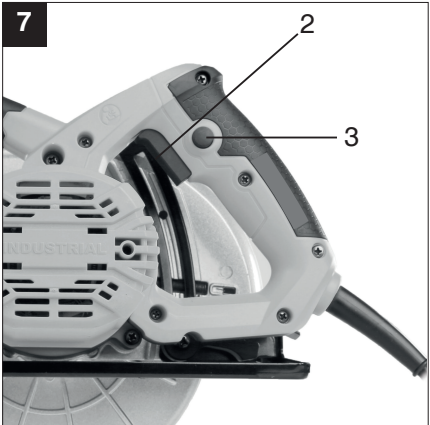
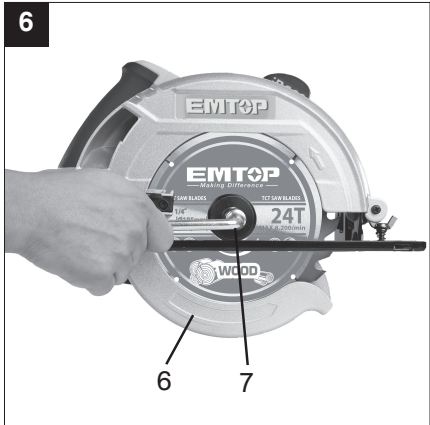
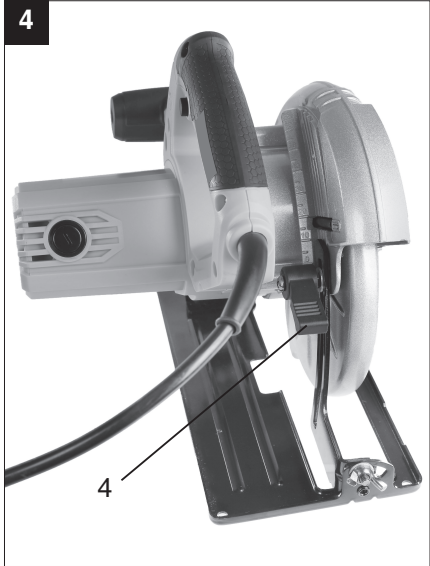

1. Description(Fig.1+Fig.2)

1. Handle
2. On/Off switch
3. Interlock button for On/Off switch
4. Locking lever for cutting depth setting
5. Power cable
6. Hinged guard hood
7. Flange
8. Saw blade
9. Parallel stop
10. Lock screw for the parallel stop
11. Lock screw for mitre cuts
12. Additional handle

Please read these instructions carefully and pay particular attention to the safety regulations. Keep the instructions together with the circular saw.

2. Technical data

Model No.	ECSW1853	ECSW18532	ECSW1853S (SAA Plug)
	ECSW1853-3 (BS Plug)	ECSW1853-6 (ISRAEL Plug)	ECSW1853-8 (BS Plug)
Voltage	220-240V~50/60Hz		
Power rating	1600 W		
Idle speed	5000/min		
Cutting depth at 45°	45 mm		
Cutting depth at 90°	65 mm		
Saw blade	185 mm		
Totally insulated	II/		

Model No.	ULCSW1853
Voltage	110-120V~50/60Hz
Power rating	1600 W
Idle speed	5000/min
Cutting depth at 45°	1-3/4"
Cutting depth at 90°	2-9/16"
Saw blade	7-1/4"
Totally insulated	II/

3. Applications

The hand-held circular saw is designed for sawing straight cuts in wood, in materials similar to wood, and in plastics.

4. Safety regulations

The corresponding safety information can be found in the enclosed booklet.

5. Working with the hand-held circular saw

Always hold the circular saw firmly.

- The hinged guard hood will be pushed back automatically by the workpiece.
- Never apply force! Advance the circular saw gently and steadily.
- The off-cut piece should be to the right of the circular saw so that the wide part of the base plate is supported over its entire surface.
- When sawing along a marked line, guide the circular saw along the corresponding groove. Clamp small pieces of wood securely before sawing. Never hold them in your hand.
- Always observe the safety regulations! Wear goggles!
- Do not use defective saw blades or blades with cracks or flaws.
- Do not use flanges or flange nuts with a hole which is larger or smaller than that of the saw blade used.
- Do not try to stop the saw blade with your hand or by applying pressure to the side of the blade.
- The hinged guard must not jam and must return to its original position once work is completed.
- Before plugging in the circular saw, check that the hinged guard is functioning properly.
- Before each use, always check that the safety devices - the hinged guard, splitter, flanges and adjustment devices - are functioning properly and have been adjusted and secured correctly.
- You can connect a suitable dust extractor to the guard hood. Check that the dust extractor is fitted securely and properly.
- The hinged guard hood is not to be wedged in the retracted guard hood when sawing.

Parallel cuts (Fig. 3)**Important! Wear ear muffs and goggles.**

1. Release the lock screw 11.
2. For 90° cuts, adjust the parallel stop 9 using the scale on groove A, for 45° cuts adjust the parallel stop 9 using the scale on groove B. Observe the saw blade width.
3. Tighten the lock screw.

Important! First make a trial cut.**Adjustment of the cutting depth (Fig. 4)**

1. Release the locking lever 4.
2. Swing the shoe downwards.
3. Adjust the cutting depth using the scale.
The saw teeth must project approx. 2 mm out of the wood.
4. Push the locking lever down

Adjustment of the cutting angle (Fig. 5)

1. Release the lock screw 11
2. Adjust the **cutting angle** to the desired angle between 0 and 45°.
3. Tighten the lock screw 11.

Changing the saw blade (Fig. 6)**Important! Pull out the plug before making any changes to the circular saw!**

1. Open the hinged guard hood 6 and hold.
2. Press the lock button.
3. Undo the screw
4. Remove the flange 7 and the saw blade by dropping down and out.
5. Clean the flange and insert a new blade. Note the direction of rotation (see arrow on the guard hood).
6. Tighten the screw and check for concentricity.

Switching on

Before pressing the On/Off switch, check that the saw blade is properly fitted, that the moving parts run smoothly and that the clamping screws are tight.

Switching on and off (Fig. 7)

- | | |
|----------------|---|
| To switch on: | Press the interlock button 2 and the switch 3 simultaneously. |
| To switch off: | Release the interlock button and the switch. |

6. Maintenance

- Keep the cooling vents on the motor housing clean and unobstructed at all times. Blow out any dust and dirt at regular intervals.
- Have a specialist workshop check the carbon brushes in the event of excessive sparking.
- Worn carbon brushes are to be replaced only by a specialist workshop or by our Customer Service Centre.
- Keep the machine clean at all times.
- Never use any caustic agents to clean the plastic parts.
- If ever you discover any damage, consult the exploded drawing and parts list to determine exactly which replacement parts you need to order from our Customer Service Centre.

1. Descripción (Fig.1+Fig.2)

1. Mango
2. Interruptor On/Off (Encendido/Apagado)
3. Botón de bloqueo par el interruptor On/Off
4. Palanca de bloqueo para el ajuste de profundidad de corte.
5. Cable de poder
6. Capucha protectora colgante
7. Brida
8. Hoja de sierra
9. Barra paralela de parada
10. Tornillo de seguridad para la barra paralela de parada
11. Tornillo de fijación para cortes a inglete
12. Mango adicional

Por favor, lea atentamente estas instrucciones y preste especial atención a las normas de seguridad. Mantenga las instrucciones junto con la sierra circular.

2. Datos Técnicos

ModeloNo.	ECSW1853	ECSW18532	ECSW1853S (SA Plug)
	ECSW1853-3 (BS Plug)	ECSW1853-6 (ISRAEL Plug)	ECSW1853-8 (BS Plug)
Voltaje	220-240V~50/60Hz		
Potencia	1600 W		
Velocidad en vacío	5000/min		
Prof. Corte a 45°	45 mm		
Prof. Corte a 90°	65 mm		
Hoja de sierra	185 mm		
Totalmente aislada	II/□		

ModeloNo.	ULCSW1853
Voltaje	110-120V~50/60Hz
Potencia	1600 W
Velocidad en vacío	5000/min
Prof. Corte a 45°	1-3/4"
Prof. Corte a 90°	2-9/16"
Hoja de sierra	7-1/4"
Totalmente aislada	II/□

3. Aplicaciones

La sierra circular de mano está diseñada para cortes rectos de aserrado en madera, en materiales similares a la madera y los plásticos.

4. Regulaciones de seguridad

La información de seguridad correspondiente se puede encontrar en el folleto adjunto.

5. Trabajando con la sierra circular de mano

- ◆ Siempre sujete la sierra circular con firmeza.
- ◆ La capucha protectora colgante puede ser apartada de forma automática por la pieza de trabajo.
- ◆ Nunca aplique la fuerza. Avanzar con la sierra circular con cuidado y de manera constante.
- ◆ La pieza fuera de corte debe estar a la derecha de la sierra circular de modo que la parte ancha de la placa base está apoyada sobre toda su superficie.
- ◆ Al cortar a lo largo de una línea marcada, guiar la sierra circular a lo largo de la ranura correspondiente.
- ◆ Fije las pequeñas piezas de madera de forma segura antes del aserrado. Nunca las sostenga con su mano.
- ◆ Respete siempre las normas de seguridad ¡Use gafas!
- ◆ No utilice hojas de sierra defectuosos o cuchillas con grietas o defectos.
- ◆ No use bridas o tuercas de la brida con un agujero que es más grande o más pequeño que el de la hoja de sierra utilizada.
- ◆ No trate de detener la hoja de sierra con la mano o mediante la aplicación de presión al lado de la hoja.
- ◆ La protección colgante no puede atascarse y debe volver a su posición original una vez que se complete el trabajo.
- ◆ Antes de enchufar la sierra circular, compruebe que la protección colgante está funcionando correctamente.
- ◆ Antes de cada uso, compruebe siempre que los dispositivos de seguridad - protección colgante, divisor, y dispositivos de ajuste - están funcionando adecuadamente y se han ajustado y asegurado correctamente.
- ◆ Puede conectar un adecuado extractor de polvo a la protección colgante. Compruebe que el extractor de polvo se instala de forma segura y adecuada.
- ◆ La Protección colgante de seguridad no se debe encajar en el protector de la hoja de corte durante el aserrado.

Cortes Paralelos (Fig. 3)

¡Importante! Use tapones para los oídos y gafas de protección.

1. Suelte el tornillo de bloqueo 11.
2. Para cortes de 90°, ajustar el tope paralelo 9 usando la escala en la ranura A, para cortes de 45° ajustar el tope paralelo 9 usando la escala en la ranura B. Tenga en cuenta el ancho de la hoja de sierra.
3. Apriete el tornillo de bloqueo.

¡Importante! En primer lugar hacer un corte de prueba.

Ajuste de la profundidad de corte (Fig. 4)

1. Suelte la palanca de bloqueo 4.
2. Gire hacia abajo el zapato.
3. Ajuste la profundidad de corte utilizando la escala.

Los dientes de la sierra debe sobresalir aprox. 2 mm de la madera

4. Empuje la palanca de bloqueo hacia abajo

Ajuste del ángulo de corte (Fig. 5)

1. Suelte el tornillo de bloqueo 11
2. Ajustar el ángulo de corte en el ángulo deseado entre 0 y 45°.
3. Apriete el tornillo de bloqueo 11.

Cambio de la hoja de corte (Fig. 6)

¡Importante! ¡Desconecte el enchufe antes de hacer cualquier cambio en la sierra circular!

1. Abra la protección colgante 6 y sostenga.
2. Presione el botón de bloqueo.
3. Afloje el tornillo
4. Quitar la pestaña 7 y la hoja de sierra dejando caer hacia abajo y hacia fuera.
5. Limpie la brida e inserte un disco nuevo. Nótese el sentido de giro (véase la flecha en el protector).
6. Apriete el tornillo y compruebe la concentricidad.

Puesta en marcha

Antes de pulsar el interruptor den encendido/apagado (On/Off), compruebe que la hoja de sierra está bien instalada, que las partes móviles no tienen problemas y que los tornillos de sujeción estén apretados.

Encendido y apagado (Fig. 7)

Para encender: Pulse el botón de bloqueo 2 y al mismo tiempo el interruptor 3.

Para apagar: Suelte el botón bloqueo y el interruptor.

6. Mantenimiento

- ◆ Mantenga las rejillas de ventilación en la cubierta del motor limpias y sin obstrucciones en todo momento. Sople el polvo y la suciedad, a intervalos regulares.
- ◆ Pida a un taller especializado que compruebe los carbones en el caso de provocar chispas excesivamente.
- ◆ Los carbones gastados deben ser sustituidos únicamente por un taller especializado o por nuestro Centro de Servicio al Cliente.
- ◆ Mantenga limpia la máquina en todo momento.
- ◆ Nunca utilice productos cáusticos para limpiar las piezas de plástico.
- ◆ Si alguna vez usted descubre algún daño, consulte el despiece y la lista de piezas para determinar exactamente qué piezas de repuesto necesita ordenar a nuestro Centro de Servicio al Cliente.

**ECSW1853,ULCSW1853,ECSW1853-3
ECSW1853-6,ECSW1853-8,ECSW1853S
ECSW18532 Exploded view**

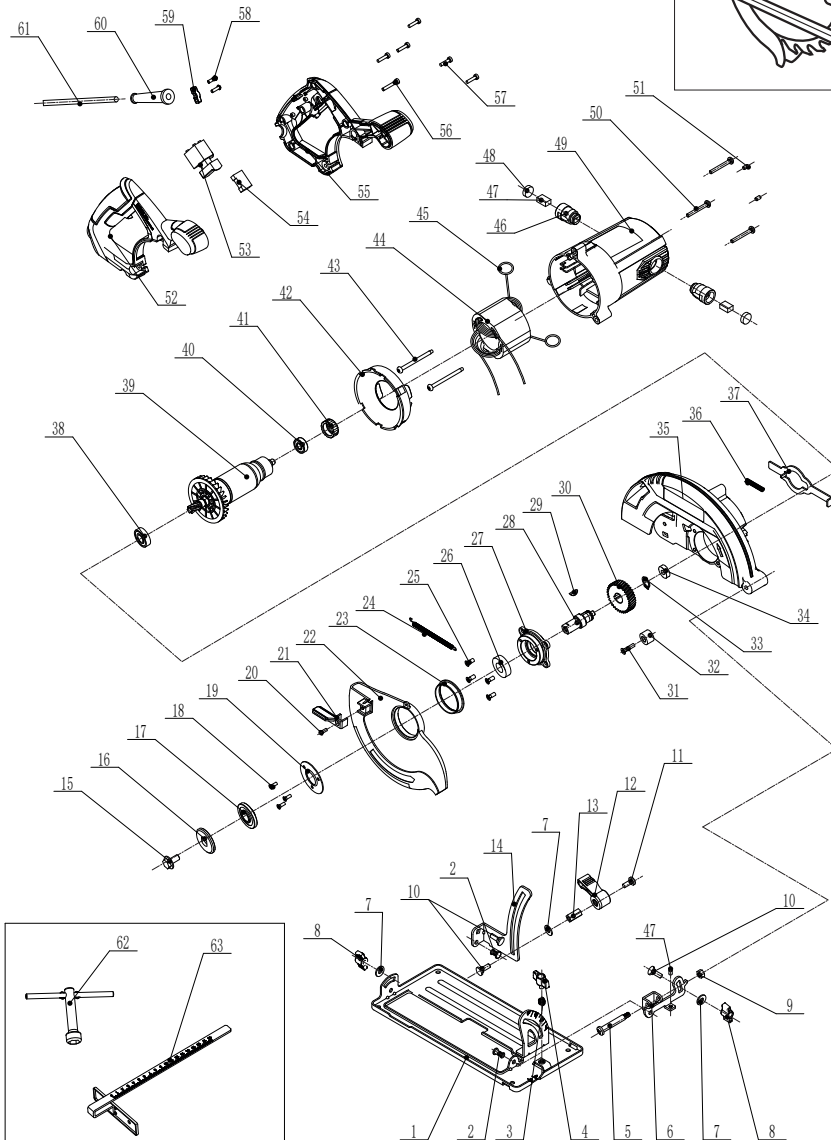
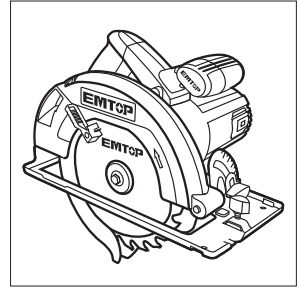



ECSW1853,ULCSW1853,ECSW1853-3,ECSW1853-6 ECSW1853-8,ECSW1853S,ECSW18532 Spare part list

No.	Part Description	Qty
1	base	1
2	rivet	2
3	spring	1
4	screw M6x12	1
5	screw $\phi 6 \times 40$	1
6	angle bracket	1
7	washer $\phi 16 \times \phi 6.5 \times 1.5$	3
8	Nut M6	2
9	Nut M5	1
10	screw M6x16	1
11	screw M6x14	1
12	Deep locking lever	1
13	Nut M6x20	1
14	depth bracket	1
15	screw M8x16	1
16	outer flange	1
17	clamping flange	1
18	screw M4x10	3
19	cover flange	1
20	screw M4x10	1
21	Spanner	1
22	blade cover	1
23	front cover	1
24	Compression spring	1
25	screw M5x12	4
26	bearing 6002RS	1
27	front cover	1
28	spindle	1
29	Woodruff key 4x13	1
30	Big gear	4
31	screw M5x20	1
32	ring	1

No.	Part Description	Qty
33	Elastic cylindrical pin	1
34	bearing 607	1
35	Head	1
36	self-locking spring	1
37	Self-locking	1
38	bearing 6001RS	1
39	rotor	1
40	bearing 608	1
41	bearings spacer	1
42	Wind fence	1
43	screw st5x65	2
44	stator	1
45	Extension spring	2
46	brush holder	2
47	carbon brush	2
48	brush cover	2
49	motor cover	1
50	screw M5x40	3
51	screw M5x8	3
52	right grip	1
53	switch	1
54	capacitor(Optional)	2
55	left grip	1
56	screw ST4X22	1
57	screw ST4X16	5
58	screw ST4X14	2
59	cord clip	1
60	cord protector	1
61	Electric cable	1
62	spanner	1
63	Parallel stop	1

EMTOP

MADE IN CHINA 1222.E05
BEST TOOLS CO., PTE. LTD.

   EMTOP International

No. 20 Dagang Road, Fuqiao Town,
Taicang City, China.

