

Remote control brushcutter

DCR55

ALNOVA

Instructions and user manual

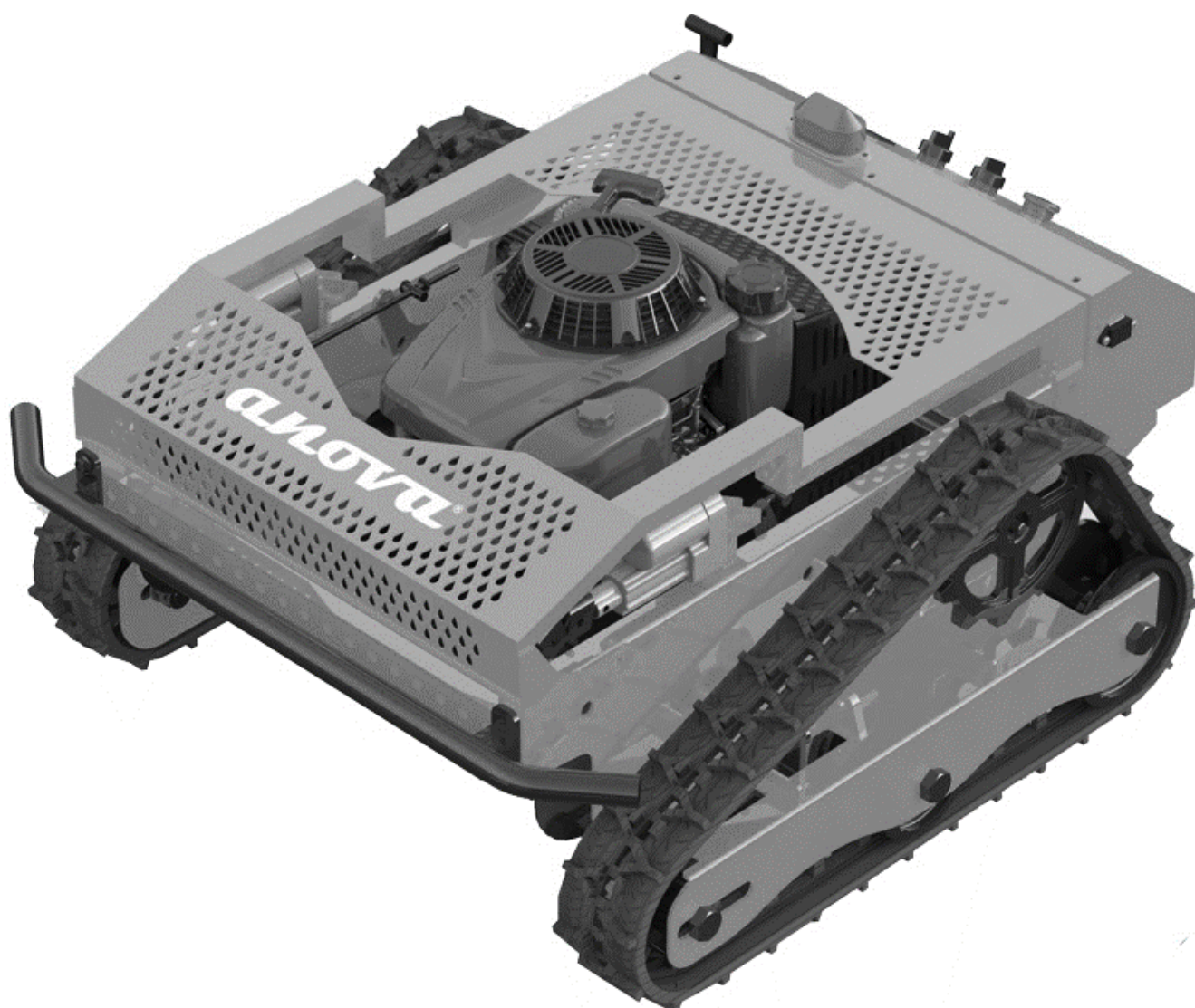

EN

Millasur SLU
Rúa Eduardo Pondal, nº 23 - Pol. Ind. Sigüeiro
15688 - Oroso - A Coruña - 981 696 465 - www.millasur.com





Anova We would like to congratulate you on choosing one of our products and guarantee the assistance and cooperation that has always distinguished our brand over time.

This machine is designed to last for many years and to be of great use if used according to the instructions in the user manual. We therefore recommend that you carefully read this instruction manual and follow all our recommendations.

For more information or questions, you can contact us through our web support at www.anova.es.

INFORMATION ABOUT THIS MANUAL

Pay attention to the information provided in this manual and on the appliance for your safety and the safety of others.

- This manual contains instructions for use and maintenance.
- Take this manual with you when you go to work with the machine.
- The content is correct at the time of printing.
- We reserve the right to make changes at any time without affecting our legal responsibilities.
- This manual is considered an integral part of the product and must remain with it in case of loan or resale.
- Request a new manual from your distributor if it is lost or damaged.

READ THIS MANUAL CAREFULLY BEFORE USING THE MACHINE



To ensure your machine delivers the best results, carefully read the usage and safety guidelines before using it.

OTHER WARNINGS:

Improper use could cause damage to the machine or other objects.

Adapting the machine to new technical requirements could cause differences between the content of this manual and the product purchased.

Read and follow all instructions in this manual. Failure to follow these instructions could result in serious personal injury.

INDEX

1. SAFETY INSTRUCTIONS
2. PRODUCT DESCRIPTION
3. TECHNICAL SPECIFICATIONS
4. INSTRUCTIONS FOR USE
5. MAINTENANCE AND CLEANING
6. TROUBLESHOOTING
7. WARRANTY
8. ENVIRONMENT
9. PARTS BREAKDOWN
10. CE CERTIFICATE

1. SAFETY INSTRUCTIONS

1.1. Safety instructions

Important

Before operating this product, please read and follow the instructions below. To prevent injury to yourself and others, you should also follow local safety regulations.

Keep these instructions for future reference. This manual contains safety information to inform you about the hazards and risks associated with the product and how to prevent them. It also contains important instructions that must be followed during product setup, operation, and maintenance.

It is important that you read and understand these instructions before attempting to operate this equipment. Make sure you are fully familiar with the controls and the correct use of the product.

Throughout this manual, you will find notices that provide safety instructions and information about hazards that could cause personal injury and/or property damage. These include a warning icon to indicate the likelihood and potential severity of injury.

- **Danger/Warning:** Indicates a hazard that, if not avoided, could result in serious injury.
- **Important/Caution:** Indicates a hazard which, if not avoided, could result in minor or moderate injury.
- **Note/Notice:** Indicates information considered important but not related to hazards.

For your safety, carefully read these operating instructions. Familiarize yourself with the controls and proper use of the device. Failure to follow these safety information and instructions may result in serious injury or death. Share these operating instructions with other users of the device.

Before starting work: Have qualified personnel show you how to safely operate the device.

First, familiarize yourself with the device in a large, open, and flat area.

1.1.1. User restrictions

Never allow children or anyone unfamiliar with the instruction manual to use the device. Individuals under 18 years of age may only operate the device under proper supervision. Local regulations determine the minimum operator age and operating time.

The following people are not suitable for operating the device:

- They are under the influence of alcohol, drugs, or medications that delay reaction time.
- Having physical and mental/emotional disabilities.
- They are tired or sick.
- People with pacemakers will not be allowed to touch any part of the ignition system that is under power.

1.1.2. Safe handling of fuel

- The fuel is toxic and highly flammable. There is a risk of burns and explosion.
- Keep fuel away from ignition sources and do not smoke while handling it.

- Do not inhale fuel vapors, they are hazardous to your health.
- Wear gloves and avoid skin contact with the fuel.
- Always refuel outdoors, with the engine cold and completely stopped. Always use a filler neck or funnel.
- Do not spill fuel or allow it to enter pipes or drains.
- If fuel is spilled, do not start the device until the vapors have evaporated (dry it). Move the device away from the spilled fuel.
- Always close the tank lid tightly and do not open it while the engine is running or the device is still hot.
- Empty the fuel tank only outdoors. Use the approved container or drain the fuel tank.
- Store fuel out of the reach of children and keep it in a suitable container in a dark, cool, and dry place.
- Never store the device with fuel in the tank inside a building where fuel vapors may come into contact with open flames or sparks.
- Immediately replace the fuel tank or tank cap if they are damaged.

First aid

In case of ingestion of fuel or inhalation of fuel vapors, do not induce vomiting and seek medical attention immediately. In case of skin contact, wash immediately with soap and water. Change contaminated clothing as soon as possible.

Fire safety measures

In case of fire, use foam, dry powder extinguisher, or carbon dioxide (CO₂). Never extinguish it with water.

1.1.3. Intended use

The device is designed for cutting and shredding grass or similar vegetation in agriculture and forestry. Woody vegetation should be no more than one year old. Any use beyond this purpose will be considered improper use.

Use only manufacturer-approved cutting tools and accessories. Failure to do so will compromise operational safety. The device user is responsible for any accidents or damage that may occur to other people or their property.

1.1.4. Checks before using it

To ensure safe operation and avoid hazards, injuries, and damage, check the device before each use.

Before each use, visually check whether the blade, drive and fastening components, cables and cable connections are in normal working condition or loose.

Do not remove, modify, or cover any parts of the safety devices or controls. Observe the maintenance instructions.

Before using it, check the device's functions and safety features (see the "Maintenance" chapter) to ensure safe operation of the device.

1.1.5. Danger zones

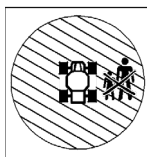

- There is a risk of injury within the device's danger zone.
- The size of the danger zone depends on the conditions of the cutting area.

Stones, debris, or other objects on the cutting surface can become caught by the blade and be ejected, causing serious injury. The area in front of and to the right of the device is especially dangerous. On uneven surfaces, the blade can...

Touch the ground and grab for hidden objects. Never work when there are people, children, or pets in the danger zone.

There is a risk of injury from the rotating blade. Keep hands and materials away from moving and rotating parts.

On slopes, the device can tip over and slide towards people, trapping them or making them roll.

There is a risk of property damage in the danger zone around the device. Ensure that no vehicles, buildings, or other property are damaged in the danger zone. Working near the road requires special care.

Pay attention to traffic when working near roads. Do not expose yourself to any risks from road traffic.

- Make sure the road is out of the danger zone and that you do not endanger any road users.
- Make sure:
 - o that people never stand in the direction of travel in front of the device.
 - o that no one positions themselves on the slope below the device.
 - o that they have a complete view of the danger zone at all times.

1.1.6. Safety instructions during operation

Danger of exhaust gas poisoning

Engine exhaust contains carbon monoxide, which can cause serious health problems or death. Do not operate the engine in an enclosed room, even if all doors and windows are open and the room appears well-ventilated.

Only use the motor after moving the device outdoors. Refer to the motor manufacturer's instruction manual.

Risk of injury from engine starting

Do not start the engine:

- When fuel was spilled.
- In enclosed or poorly ventilated premises (danger of poisoning!).
- When other people are in immediate proximity.

Risk of injury when the blade is in operation

Turn off the blade and wait until it stops.

- when driving on surfaces other than grass.
- when the grass is not cut.
- when the area to be cut cannot be completely bypassed.
- when it is necessary to maneuver the device to remove it from a dangerous position.

Risk of injury when the engine is running

Turn off the engine, wait for the blade and engine to stop, and remove the ignition key.

- before transporting the device.
- before moving away from the device, even for a short period of time.
- before cleaning or checking the device or before performing any work on the device.
- before unlocking or uncovering the download area.

1.1.7. Personal protective measures before the operation

When mowing the lawn, always wear safety shoes with good traction and long trousers. Do not mow the lawn in open sandals or barefoot. Use safety gloves to protect yourself from injury and vibration.

Noise causes health problems. Use hearing protection to prevent hearing damage. Wear safety glasses and a helmet.

1.1.8. Preparation of the cutting area

Before mowing the lawn, carefully check the perimeter. Remove stones, pieces of wood, bones, wire, and other objects.

that could be collected and thrown away by the device.

Remove live wires from the cutting area. These can be damaged during cutting and cause an electric shock or short circuit.

Note: When the shape of the lawn is not clear, first adjust the cutting head to the highest position and then adjust the cutting head to the appropriate height after the ground is clear.

1.1.9. Other risks during operationRisk of injury

Make sure that help can be provided in case of emergency.

Mow the lawn only during daylight hours or with adequate artificial lighting. Never mow the lawn in unstable weather conditions or when there is a risk of lightning.

Take special care when mowing the lawn in soft ground, near landfills, ditches, ditches and water edges.

Do not transport any person on the device.

Be very careful when moving and mowing the lawn in reverse.

Cut surfaces with a fire hazard

- Carry with you a sufficient quantity of suitable extinguishing agent.
If the side tilt is too great, fuel could leak from the carburetor or tank. This poses a fire hazard!
- Observe the cut surface even after completing the movement to ensure that no fire starts.
To avoid the risk of fire, keep the following components free of dirt, grass, hay, oil leaks, grease, etc.:
Engine
Exhaust (manifold, protection, clearances)
Battery

Area around the fuel tank

1.1.10. Safety instructions for working on slopes

If the device, while in use, stops on steep terrain or the engine shuts off, the device may roll.

Risk of sliding and overturning

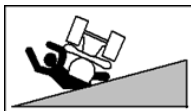

There is a risk of injury when driving on slopes due to rollovers or skidding. Please heed the following warnings.

- Do not mow excessively steep slopes $\leq 30^\circ$.
- Be very careful when changing direction.
- Do not turn on a slope.
- Do not start or brake abruptly.
If it encounters obstacles such as roots, branches, rocks, mounds, etc., the device may tilt or slip.
- Drive only when you know the terrain conditions and it is free of obstacles.
- Pay attention to potholes, holes, and other visible hazards.
- Do not drive near hazardous areas (e.g., walls, slopes, steep descents, water edges, etc.).

If the device tilts or slips

- Never attempt to stop a device that is tilting or sliding. Serious injury could result.
- Remove any spilled fluids (oil, fuel, battery acid) from the device and the ground. Disposal of the contaminated soil must be environmentally friendly, in accordance with local regulations.
- The device may have imperceptible damage. In case of malfunction, there is a risk of injury. Have the device checked by an authorized service center.

1.1.11. Precautions after the operation

- After mowing the lawn, always close the fuel valve.
- Before leaving the device, wait until the engine stops and remove the ignition key.
- After turning it off, let the device cool down for at least 20 minutes before storing it in a dry, enclosed, and well-ventilated room.
- Never place the device with gasoline in the tank inside a building where gasoline vapors may come into contact with open flames or sparks.
- Take care during maintenance and repair.

1.1.12. Precautions during maintenance

- Only perform the tasks described in these operating instructions. Submit all other tasks to an authorized service center.
- Use only manufacturer-approved blades and replacement parts. Using unauthorized blades and replacement parts can cause serious injury.
- Before performing any maintenance work, wait until the engine has stopped and disconnect the spark plug connector.

1.2. Residual risks

Important

Even if it complies with the relevant product safety regulations, residual risks may exist given the characteristics of the equipment and the work for which it has been designed.





Residual risks can be minimized by following safety instructions.

- You will reduce the risk of personal injury and damage to equipment if you follow these instructions and are careful.
- Failure to comply with these safety instructions may result in injury to the operator or damage to property.
- Lack of care, improper use, or failure to comply with safety regulations can result in injuries to the hands and fingers when the wedge is in motion.

Note: Even if you take preventive measures, there may be residual, non-obvious risks.

1.3. Symbols

The following symbols are used in these instructions for use to indicate special hazards.

	Warning. These symbols denote special hazards.
	Prohibition sign. These symbols denote unacceptable procedures.
	Directive sign. These symbols indicate the necessary protective measures.
	Hot surface. Do not touch the engine or muffler. They get very hot during operation and you could get burned.

Symbols in the text

A numbered text prompts you to take action or displays a process sequence.

- A bloody arrow marks the result of a step.
- An arrow that is not indented refers to the result of a sequence of actions.

Note: Additional information is marked by the word "Notice" written in bold letters.

Warning

In these instructions for use, warnings are indicated by keywords. These keywords are used to indicate the following hazards and their possible consequences.

2. PRODUCT DESCRIPTION

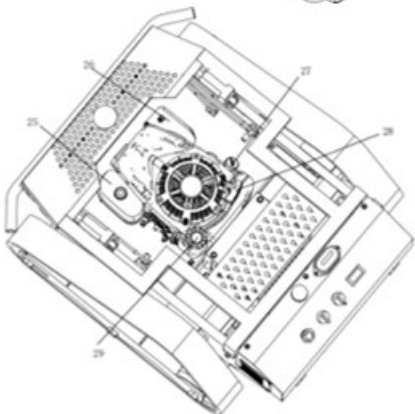
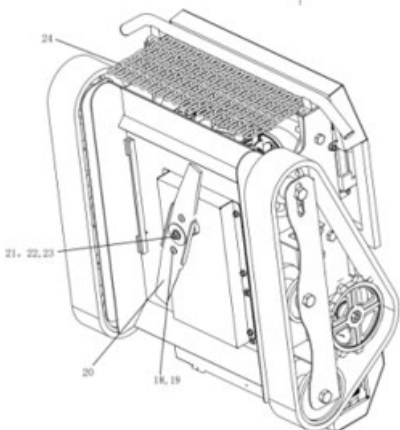
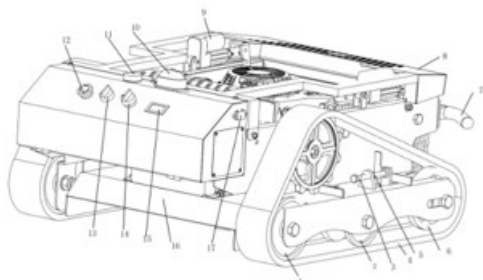

1. Rear load wheel assembly
2. Center load wheel assembly
3. Tighten the bolt
4. Rubber tracks
5. Tighten the nut
6. Front guide wheel assembly
7. Front bumper
8. Soldier upper shield
9. Electric push rod
10. Warning light
11. Antenna
12. Emergency stop switch
13. Ignition switch
14. Electric start switch
15. Displaying the battery voltage and energy level
16. Chassis
17. 24V Charging Port
18. Square bolt
19. M10 Nut
20. Blades
21. Bolts, 3/8-24UNF
22. Large flat pad
23. Seat joint
24. Grass Lock Chain
25. Air filter
26. Escape
27. Oil dipstick
28. Starter handle
29. Fuel tank cap

2.1. Remote control of each operating key function

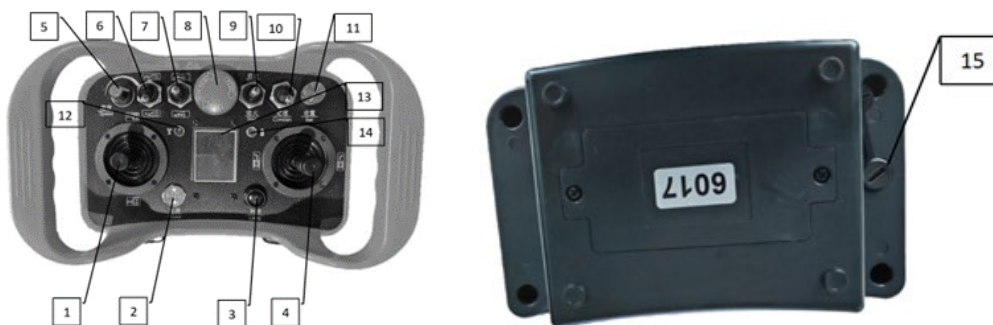

1. **Strait rocker:** Push the machine forward and backward. There is no function on either side.

2. Remote control power switch Press the remote control to turn on, then press the remote control to turn off.
3. Light switch This key is temporarily unavailable.
4. Joystick rotation Push left and the machine will turn left; push right and it will turn right. There are no functions on the front or back.
5. Speed adjustment knob: It is used to adjust the speed when the machine is going straight or turning.
6. Quick-turn switch Push forward to perform the U-turn action with a click and push back to reset and stop the U-turn action.
7. Cutting head lift switch The forward thrust of the cutting head rises, the backward thrust of the cutting head descends, and the action of releasing the cutting head stops.
8. Emergency stop switch After pressing, the machine stops moving and the motor turns off. To repeat the action, turn the switch to the right to release it.
9. Engine start/stop switch Push the motor up to start it, push it down to stop it, and release the button to return it to its original position.
10. Cruise control switch The upward-pumping machine moves at a constant speed in a straight line, while the downward-pumping machine stops.
11. Settings button This button is not in use at the moment.
12. Signal transmission indicator light
13. Remote control display screen
14. Power indicator light
15. Remote control charging port

2.2. Control panel key functions

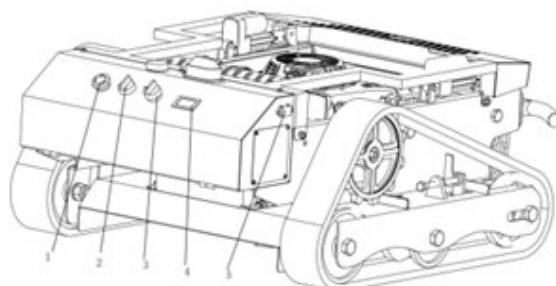

1. **Emergency stop button**
It is used in case of emergency to shut down the engine and turn off the entire machine system.
2. **Power button**
It is used to turn electronic control systems on and off.
3. **Electric starter switch**
It is used to turn off, run, and start the engine.
 - a. OFF: On/Off, key can be removed
 - b. RUN: Execution status
 - c. START: Electric start.
4. **Voltage and load meter**
It is used to indicate the battery voltage and charge.
5. **24V charging port**
It is used to charge 24V batteries.

3. TECHNICAL SPECIFICATIONS

Characteristics	
Engine	4t – LONCIN LC1P75F (EURO V)
Engine displacement	224 cc
Power	6.1 hp - 4.5 kW/3600 rpm
Starter type	Manual and electric
Engine oil tank capacity	0.5 l
Walking speed	0-5 km/h
Remote control distance	200 m
Cutting width	54 cm
Blade type	1 fixed support with 2 floating blades
Work pending	20°
Weight	160 kg
Cutting height	20-140 mm
Fuel tank capacity	1.4 l
Cutting height adjustment	Electric
Traction	Using electric motors

Note: Due to design improvements and/or changes in specifications, this manual may be modified without prior notice and without needing to change the document.

4. INSTRUCTIONS FOR USE

4.1. Before we begin

Checking the oil level

An incorrect oil level can damage the engine.

Before each use, check the engine oil level as indicated in the "Maintenance" section.

Fuel

Use unleaded gasoline as fuel (refer to the engine manufacturer's operating instructions).

You can use E10 fuel. Do not store it for more than 30 days.

Do not use E85 fuel. The fuel must contain less than 10% ethanol.

Refueling

⚠ Warning

The fuel ignites when the hot parts of the engine are heated.

Before refueling, turn off the engine and wait at least 20 minutes for it to cool down. Observe the fuel safety instructions.

Fill the fuel tank

1. To refill, use a container with a filling spout or a funnel.
2. Open the container carefully to slowly reduce any excess pressure.
3. Open the tank cap carefully so that the excess pressure slowly reduces and no fuel escapes.
4. Fill the fuel tank.
5. Tightly close the tank cap again.

⚠ Danger

Danger of poisoning from toxic exhaust gases.

- Do not operate the motor in enclosed or poorly ventilated rooms.
- Please note the safety instructions regarding the risk of poisoning.

⚠ Danger

Danger of electric shock from live wires in the cutting area. Live wires can be damaged during cutting and cause an electric shock or short circuit.

- Make sure the cutting area is free of live wires.

⚠ Warning

There is a risk of injury during startup due to the rotating blades.

- Make sure no one is in the blade's danger zone

Engine start

Only start the device when it is on level, firm ground.

Testing

1. Unscrew part 1 to check if the engine oil level is between the upper and lower marks. If the oil level is insufficient, add engine oil until it reaches the level between the upper and lower marks.
2. Unscrew part 2 to check for fuel in the tank. If there is not enough, add 92# gasoline.

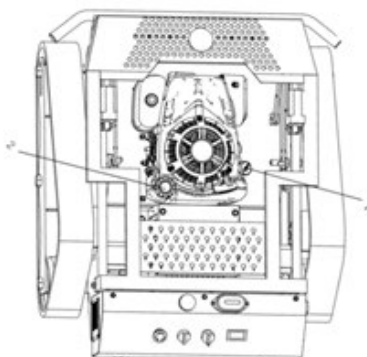

3. Check if the remote control keys are in the initial position. For example, item 6 is in the pushed position, item 7 is in the middle position, item 8 is in the connected position, item 9 is in the middle position, and item 10 is in the pushed position. If they are not in the initial state, they need to be reset.



4.2. Start operation

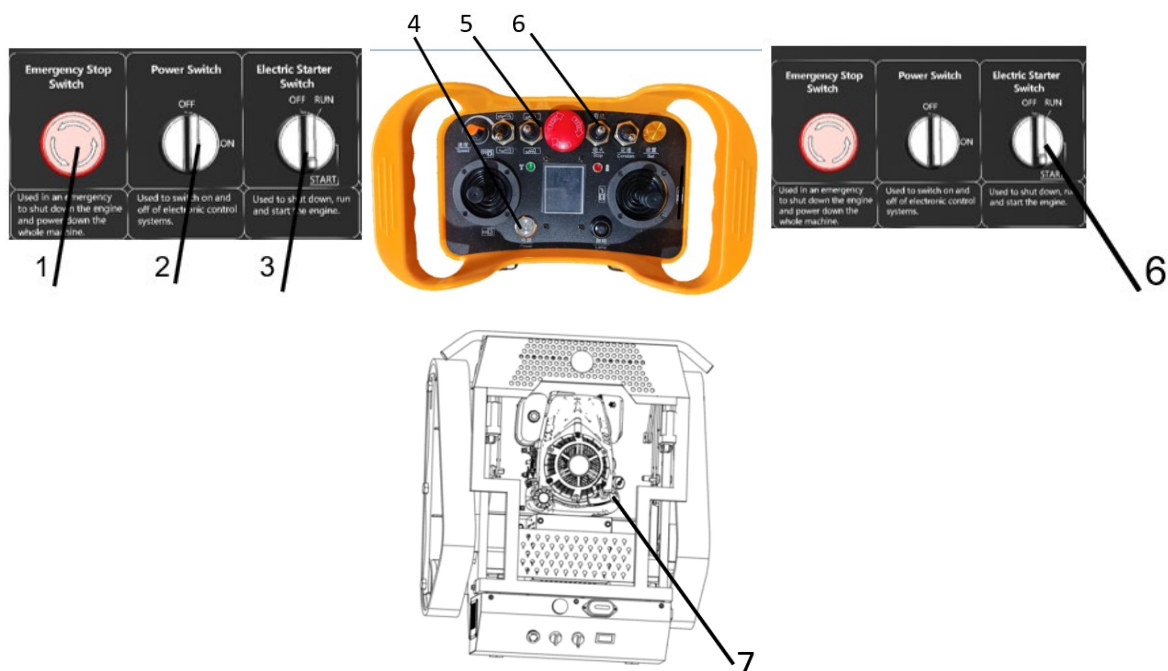

1. Release the emergency stop switch with the right side in the ON position.
2. Turn on the power switch to turn on the power; at this time, the fault indicator is on and the voltage and electricity meter are displayed.
3. Screw the electric starter switch to the "Run" position.
4. Turn on the power switch on the remote control.
5. Press the remote control's cutter head lift switch to raise the cutter head to the mid-high position.
6. Turn the electric starter switch from the "run" position to the "start" position. Start the engine. After starting, release the ignition key. You can also start the engine with the remote control. Simply press the starter switch on the remote control to start the engine.
7. This gasoline engine can also be started manually. Pull the starter handle on part 7 by hand to start it.

Note:

1. The motor speed of this machine adjusts automatically and no adjustment is required.
2. If the engine does not start after 8 seconds, release the key or the remote control's start switch, wait about 15 seconds, and restart the device again.
3. This engine is equipped with an automatic damper and no adjustment is required when starting the engine.

4.3. Power off and park

▲ Warning

Risk of injury in case of unauthorized use.

- Always remove the ignition key when not using the device



1. Turn the ignition key to the "OFF" position and turn off the gasoline engine. Alternatively, use the remote control to turn off the engine; press the switch until the gasoline engine shuts off completely.
2. Turn the power switch to the OFF position to turn it off.
3. Turn off the remote control's power switch and turn it off.
4. In case of emergency, pressing element 4 can also turn off the motor and stop the machine.
5. Wait until the engine has completely stopped before leaving the device.
6. Remove the ignition key.

4.4. Information about lawn mowing

Before mowing the lawn, check that the device is complete, functioning properly, and clean. A dirty ventilation grille causes the motor to overheat, which can damage it. A dirty protective grille on the muffler can pose a fire hazard.

Do not mow the lawn when it is wet or raining. It could be damaged and there is a risk of slipping!

Turn the device only on sections that have already been mowed. Do not leave it unattended with the motor running.

Adjust the cutting height so that the blade does not touch the ground, even on uneven terrain. Always place the blade in the transport position when not mowing.

To mow the lawn, always turn the throttle lever to full acceleration for the best cutting performance.

Component	Action	Maintenance interval	
		TO	B
Fuel	Check the fuel level.	■	
	Is the tank lid closed?	■	
Tank, fuel valve, and fuel line	Inspect the parts for leaks and verify that they are in good condition.	■	▲
Ventilation grille	Clean.	■	▲
Engine cooling	Clean.		▲

Spark plug	Check/replace.		▲
Air filter	Keep.	■	■▲
Sheet and fixing components	Check for wear and damage	■	▲
	Change.		▲
	Clean the threaded tip of the knife blade.	■	
V-belt	Are the belts properly tensioned, without cracks, and in good condition?		▲
Chassis and impact protection	Check for rust and cracks and inspect the weld seams.	■	▲
	Are all protective devices and covers in place, properly secured, and functioning correctly?	■	▲
Engine	Consult the engine manufacturer's operating instructions..	■	▲
	Check the oil level (refer to the engine manufacturer's operating instructions).	■	▲
	Oil change (see engine manufacturer's operating instructions).		▲
	Change the oil filter (see the engine manufacturer's operating instructions).		▲
ignition lock	Verify that it is working correctly.	□	▲
Battery	Check the charging conditions.		▲
<p>A → Before and after each use. B → Annually or every 50 hours. ■ → By the user when the engine is not running. □ → By the user when the engine is running. ▲ → Through the authorized service center.</p>			

5. MAINTENANCE AND CLEANING

5.1. Maintenance

▲ Danger

Danger of poisoning from toxic exhaust gases.

- Do not operate the motor in enclosed or poorly ventilated rooms.
- Please take note of the safety instructions regarding the risk of poisoning.

Risk of injury from unexpected movements. During inspections, the device may move unexpectedly.

- Make sure there are no people or property in the danger zone.
- Make sure that no further hazards occur if an unexpected movement takes place.

▲ Warning

Risk of injury during maintenance and cleaning work when the engine is running.

- Perform maintenance tasks only with the engine running if required in the Maintenance table

Before performing any maintenance and cleaning work when the engine is not running:

1. Let the device cool down for at least 20 minutes.
2. Close the fuel valve.
3. Disconnect the negative terminal of the battery.

Improper maintenance can make the device unsafe and cause accidents. Regular maintenance keeps the device ready for use.

Perform device maintenance according to the following maintenance instructions.

Contact an authorized service center if problems arise during maintenance or if you detect deficiencies during one of the following inspections.

5.1.1. Maintenance and cleaning station

⚠ Warning

Risk of injury due to the device's weight. The device could tip over and cause serious injury.

- Please note the following instructions

To perform maintenance, repair or cleaning tasks on the bottom of the device, you can lift or tilt the device.

- Lift the device only when it is on level, firm ground.
- Only use lifting equipment or ramps suitable for the weight of the device.
- Attach the lifting mechanism only to the main frame, as only this can support the weight.
- Always secure the device so that it does not tip over, fall, or slide.
- Do not stand in the tilt zone of the device.
- Tilt the device at an angle not exceeding 30°. Otherwise, the equipment could tilt and be damaged or contaminated due to a fuel leak.
- Do not perform tasks that could cause the device to tilt, fall, or slip.

5.1.2. Maintenance overview

For maintenance and cleaning work, always use gloves and safety glasses.

5.1.3. General inspection

To ensure safe operation of the device, periodically check that all nuts, bolts, screws, fuel lines, and air filters are securely connected. Check the ignition cable and spark plug cap for damage.

Immediately replace damaged or worn parts, especially blades, protective covers, mufflers, or fuel tanks.

Check the fuel tank, fuel valve, fuel line, carburetor, engine, transmission, battery, and other fluid-containing parts for leaks and proper function. If a leak is found, contact an authorized service center.

Check the rubber seal on the base of the cutting head for damage and replace it if necessary. Failure to replace it may result in debris being ejected from the base of the head.

5.1.4. Blade check

⚠ Warning

Wear or damage to the blades and fasteners can cause the blades or fasteners to detach.

- Check the blades and all fastening elements according to the following instructions.

There is a considerable risk of injury due to improperly mounted and maintained blades.

- Blade work must be performed by an authorized service center.

Wear heavy-duty gloves when inspecting the blade. Working on the blade requires specific knowledge because it's necessary to check for imbalance and observe the torque settings.

Dull blades increase the workload on the device and can cause cracking or breakage due to vibration.

Check the blade and all fasteners for wear, damage, and cracks.

- Every time before and after mowing the lawn.
- In case of noticeable changes or unusual vibrations.

Contact an authorized service center if you detect faults or damage during the inspection.

All blade parts shown and their fasteners must be replaced

- if damage or cracks are detected.
- if unusually strong vibrations occur.
- at least once a year or every 50 hours of operation, regardless of whether there is wear and tear or not.

The material weakens and can crack, endangering people and property. The resulting flying fragments can cause serious injuries.

Unusual vibrations are an indication that

- The blades are missing or broken.
- The blade is excessively worn, either on one side or
- damage to the motor or to the attachment of the cutting platform.

5.1.5. Blade change

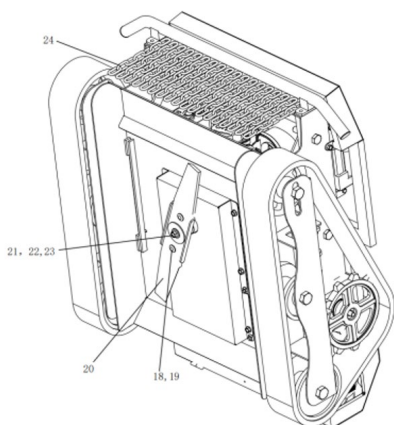

⚠ Caution

When replacing the blade (21), the fixing bolts and nuts must be replaced at the same time, and the replacement must be coated with thread-locking glue.

Always use replacement parts approved by the manufacturer.

5.1.6. Adjustment of the rubber track

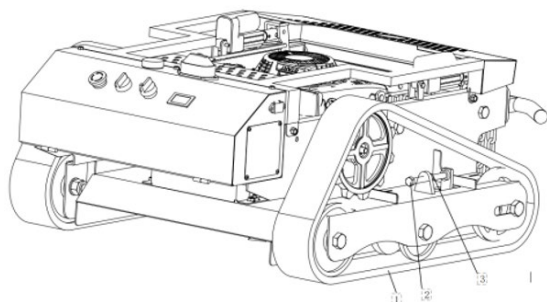

1. Rubber track
2. Tighten the bolt
3. Tighten the nut

After a certain period of use, the rubber track will stretch and need adjusting. To do this, first loosen the lock nut and then tighten the adjusting bolt with a wrench. The track should be adjusted so that it rests on the carrier wheel with a force of 20-30 mm, maintaining equal tension on both sides.

5.1.7. Checking the engine oil level

An incorrect oil level can damage the engine.

- Before each use, check the engine oil level.

The oil level should never be too low; otherwise, the engine could be damaged. When driving uphill, the oil level should always be at the upper mark.

Never overfill with oil. Otherwise, oil could get into the air filter and damage it.

Please refer to the information in the engine manufacturer's instruction manual.

5.1.8. Checking the spark plugs

▲ Danger

The ignition system generates an electromagnetic field.

- People with pacemakers should not work on active parts.

Dirty spark plugs reduce engine power. Clean the spark plug electrode with a brass wire brush. Check the electrode gap (refer to the engine manufacturer's operating instructions). Ensure the insulator surrounding the electrode is not damaged. Never use a damaged spark plug.

Tighten the spark plug using the correct torque (refer to the engine manufacturer's operating instructions).

5.1.9. Air filter maintenance

▲ Warning

There is a risk of fire and explosion due to the cleaning products.

- Never clean the air filter with flammable solvents.

Make sure the air filter is always clean. A dirty air filter reduces engine power and increases wear and fuel consumption. Regardless of operating hours, change the filter at least once a year. Do not operate the engine without the air filter.

Please refer to the information in the engine manufacturer's instruction manual.

⚠ Warning

Batteries can be dangerous.

- Keep children away.
- Never make any changes to the battery.
- The battery is sealed and should never be opened.
- For any work on the battery or battery cables, wear safety glasses and gloves.
- In case of an accident involving battery acid, always contact a doctor.

⚠ Warning

Danger of explosion

Charging the battery generates explosive gases. A battery explosion can cause injury and blindness.

- Keep away from open flames and ignition sources and do not smoke.
- Charge the battery only in well-ventilated rooms.

⚠ Warning

Danger of chemical burns

Batteries contain acids. Contact with battery acid can cause blindness or severe burns.

- Always keep the battery upright and do not spill battery acid.
- Avoid contact with skin and eyes.
- If battery acid comes into contact with your eyes, rinse them immediately with water.

If the starter motor does not start or does so insufficiently, charge the battery.

The battery requires no maintenance.

Use electronically controlled charging systems. These systems detect the connected battery, charge it with the necessary current, and end the charging process when the battery is fully charged.

Use a charger with a 12V/24V interface to connect to a standard socket and plug the charger into the standard socket.

Charge the battery before storing the device for the winter. A fully charged battery lasts approximately 4 months before needing to be recharged.

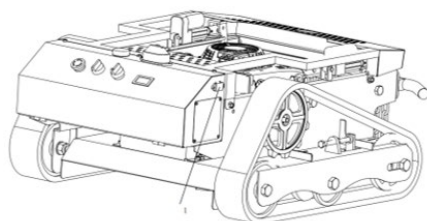

1. 24V square socket

5.1.10. Battery replacement

⚠ Warning

When working with the battery, there is a risk of short circuit.

- Do not place tools or metal objects on the battery.
- When disconnecting and connecting the battery, observe the order of the assembly steps.

⚠ Important

Use only original batteries.

You can purchase genuine batteries from the manufacturer or their authorized service center. Also, refer to the battery's instruction manual (if available).

Important note: Never confuse the plus and minus terminals.

1. Disconnect the black (-) cable.
2. Disconnect the red (+) cable.
3. Remove the battery from the device.
4. Install the new battery in the device.
5. Connect the red (+) wire.
6. Connect the black wire (-).

5.2. Storage

⚠ Danger

Danger of poisoning from toxic exhaust gases.

- Do not operate the motor in enclosed or poorly ventilated rooms.
- Please take note of the safety instructions regarding the risk of poisoning.

⚠ Warning

Fire danger

Some parts of the device may become very hot during operation, and this could cause a fire.

- Please observe the safety instructions regarding the risk of fire. Risk of injury in case of unauthorized use.
- Always remove the ignition key when not using the device.

5.2.1. Device storage

Store the device in a closed, dry, and well-ventilated place, out of the reach of children. Always repair any malfunctions before storing the device to ensure it continues to function properly. Allow the motor to cool down before storing it in an enclosed space.

Please also take into account the storage instructions contained in the accompanying operating manual from the engine manufacturer.

5.2.2. longer storage

1. Please note the safety instructions for handling fuel.
2. Empty the fuel tank.
3. Carburetor draining: Close the fuel valve, start the engine and let it run until it stops on its own.

4. Thoroughly clean the device
5. Touch up any possible damage to the paint finish.
6. Remove the ignition key and store it separately from the device.

Before storing it for an extended period, for example, in autumn, have an authorized service center check the device.

Also refer to the storage information in the engine manufacturer's instruction manual.

5.2.3. Spare parts

The reliable and safe operation of the device also depends on the quality of the replacement parts used. Use only replacement parts and accessories approved by the manufacturer. If unauthorized parts are installed, the warranty will be voided for those parts, the device, and any resulting damage.

6. TROUBLESHOOTING

The following table contains the most common problems and their solutions. If further problems arise, contact your nearest authorized service center.

Note: If you cannot resolve the product issues, please contact your official distributor.

Problem	Possible cause	Resource
The remote-controlled gasoline engine starter motor is not turning.	1. The battery is dead. 2. The ignition key is not in the "on" position.	1. Charge the battery (see section "Check the battery.") 2. Turn the switch key to "RUN"
	Battery failure	Battery replacement (Authorized Service Center).
Engine failure	Fuel valve closed.	Open the fuel valve.
	There is no fuel in the tank.	Refuel.
	The choke is open.	Close the choke.
	The unit tilts and an oil leak occurs in the air filter.	Replace the air filter, unscrew the spark plug and start it several times with the fuel valve closed, dry the spark plug and turn it back on.
	The engine flooded with oil due to too many starting attempts.	With the fuel valve closed, unscrew the spark plug and fire it several times, dry the spark plug and then screw it back in.
	The spark plug connector is removed.	Follow the safety instructions! Reattach the spark plug connector.
	The air filter is dirty.	Perform air filter maintenance (see chapter "Maintenance").
The remote control device is not moving	The spark plugs are dirty, damaged, aged or incorrect electrode gap.	Clean the spark plugs and check the electrodes Spark plug gap (see chapter "Maintenance"). Replace spark plugs if necessary.
	Circuit breaker overload trip.	Open the electrical box and close it again.
	The unit is defective. Remote control failure	Change. Change.
irregular noises	Blade imbalance caused by residue on the blade.	Have the blade resurfaced at an authorized service center. Replace the damaged blade immediately.
	The blade's drive shaft bent due to a collision with a foreign object.	Authorized service center.
	The engine fasteners are loose.	Authorized service center.

	The sheet is loosely attached.	Authorized service center.
	The fastener is loose.	Authorized service center.
	The muffler is faulty.	Authorized service center.
The engine is smoking	The air filter is dirty or soaked with oil.	Maintain or replace the air filter (see chapter "Maintenance").
	The oil level is too high.	Have an authorized service center come down the oil level up to the mark.
The engine is overheating	The ventilation grille is dirty.	Clean the ventilation grille.
	The oil level in the engine is too high. low.	Fill the engine oil (refer to the engine manufacturer's operating instructions).
	The engine cooling fins are dirty.	Have an authorized technician clean the cooling fins. service center.
The engine no disconnect	The shutdown system is faulty.	Close the fuel valve. Authorized service center.
After operating for a period of time, the drive wheel only rotates on one side and cannot go in a straight line.	Program execution disorder	Turn off, turn off the power, turn on again.

Note: If you have any questions or problems persist after performing the above operations, please contact your official distributor.

6.1. Device cleaning

After each use, you should thoroughly clean the device, especially the bottom and the blade.

Clogging grass or debris affects lawn discharge and cut quality. For proper engine cooling, keep the engine cover, vent grille, and engine clean.

▲ Warning
Fire danger

Pay special attention to ensuring that the muffler components are clean.

To clean, use a hand brush. Remove stubborn dirt with a wooden or plastic spatula. Wipe the exterior parts of the casing with a cloth.

Do not rinse the device with pressurized water or a high-pressure cleaner. Do not use harsh cleaning products.

7. WARRANTY

If your product suffers any manufacturing defect during the established warranty period, please contact or go directly to your point of sale with the necessary documentation.

Your purchase receipt should be kept as proof of the purchase date. Your tool must be returned to your distributor in acceptable and clean condition, in its original molded case, if applicable, along with your corresponding proof of purchase.

7.1. Warranty period

The legal warranty period for the product begins on the original date of purchase by the first initial buyer and its duration will be that established by the Royal Decree-Law on the protection of consumers and users against situations of social and economic vulnerability of the year corresponding to the time of acquisition of the product.

Some countries do not have limitations on how long an implied warranty lasts or do not allow the exclusion or limitation of consequential or incidental damages, in which case the above limitation and exclusion may not apply to you. This warranty gives you specific legal rights, and you may also have other rights that vary from state to state or country to country.

7.2. Exclusions

This warranty does not cover product damage or performance problems caused by:

- Natural wear and tear from use.
- Misuse, negligence, careless operation, or lack of maintenance.
- Defects caused by improper use, damage caused by handling by personnel not authorized by Anova or use of non-original spare parts.
- Defects in normal wear parts, such as bearings, brushes, cables, plugs or accessories such as drills, drill bits, saw blades, etc.
- Damage or defects resulting from abuse, accidents, or alterations.
- Incorrect use and storage (explicit reference to the fact that the rules described in the operating instructions have not been followed).
- Wear and tear caused by the customer (e.g., broken saw blades, consumed carbon brushes, etc.).
- Wear and secondary damage due to lack of maintenance, repair, lubricants (e.g., overheating damage due to blocked cooling slots, bearing damage as a result of dirt, frost damage, etc.)
- Damage as an obvious result of overuse/overload.
- Damage caused by inappropriate supplies (e.g., incorrect fuel)
- Load-induced breakage of housing components or accessories due to abnormal stress
- Load-induced deformation of the housing components or accessories due to abnormal stress.
- Damage resulting from the operation of supplies that are overfilled or leak due to improper storage, improper cleaning agents, or other damaging chemical components.
- Damage due to improper exposure to extreme temperatures (e.g., frost cracking, thermal deformation of components, etc.)
- Damage from permanent exposure to ultraviolet radiation.
- Damage caused by inadequate maintenance.
- Any damage caused by failure to follow the instructions in the instruction manual
- Any product that has been repaired by an unqualified professional.
- Any product connected to an unsuitable power source (amps, voltage, frequency).
- Any damage caused by external influences (water, chemicals, physical, impacts) or foreign substances.
- Use of unsuitable accessories or parts.
- It does not cover defects in normal wear and tear parts, nor does it cover damage or defects resulting from abuse, accidents or alterations, nor transportation costs.

Furthermore, the warranty is voided if the product has been altered or modified, or if the trademark/serial number of the machine has been defaced or removed.

Routine maintenance, tuning, adjustments, or normal wear and tear are not covered under this warranty.

This manual does not cover all possible situations regarding warranty exclusions; for more information, please contact your nearest Anova distributor.

7.3. In case of incident

The warranty must be correctly completed with all the requested information, and accompanied by the purchase invoice.

Anova reserves the right to refuse any claim where the purchase cannot be verified or where it is clear that the product was not properly maintained (maintenance, clean ventilation slots, lubrication, regularly maintained carbon brushes, cleaning, storage, etc.).

Private use is defined as personal domestic use by an end consumer. Commercial use, on the other hand, means all other uses, including uses for business purposes, income generation, or rental. Once the product has been used for commercial purposes, it will be considered a commercial product thereafter for the purposes of this warranty.

These are our standard warranty terms, but occasionally there may be additional warranty coverage not specified at the time of publication. For more information, please contact your nearest authorized Anova dealer or visit www.millasur.com.

Warranty service is only available through authorized Anova distributors. You can find your nearest distributor on our distributor map at www.anova.es.

8. ENVIRONMENT



It is essential to ensure that products and their components are disposed of responsibly to protect the environment. Below, you will find general guidelines for the proper disposal of various materials used in your machine.

Dispose of your machine in an environmentally friendly way. We shouldn't throw machines away with the regular household waste. Their plastic and metal components can be sorted according to their type and recycled.

When disposing of machinery or metal products, it's important to remember that their metal components, such as iron, steel, or aluminum, must be properly recycled at metal recycling facilities. This will contribute to their potential reuse in the manufacture of new products.

Oils and Fuels

Used oils and fuels, among other things, must be recycled properly. Do not pour these liquids down drains, into soil, rivers, lakes, or seas, as they can cause serious environmental damage. Take them to a recycling center or specialized collection point. This process helps prevent water and soil contamination and allows for the safe reuse of oils, if possible.

Plastics

Plastics should be separated and taken to designated recycling points. Do not throw them away with regular household waste. Plastics can be recycled, helping to reduce waste.

Cardboard

Packaging materials, such as cardboard, are recyclable. Be sure to separate clean, dry cardboard and place it in designated recycling containers or at an official waste collection point. Do not dispose of it with household waste.

Batteries

Batteries and other electronic components from machines must be disposed of at designated collection points to prevent the release of toxic substances into the environment. Do not throw them away with regular trash. Take them to appropriate recycling centers for safe and responsible handling.

By following these guidelines, you contribute to environmental protection and resource conservation. For more information on material disposal and recycling, please contact your local authorities and consult the necessary information.

9. PARTS BREAKDOWN

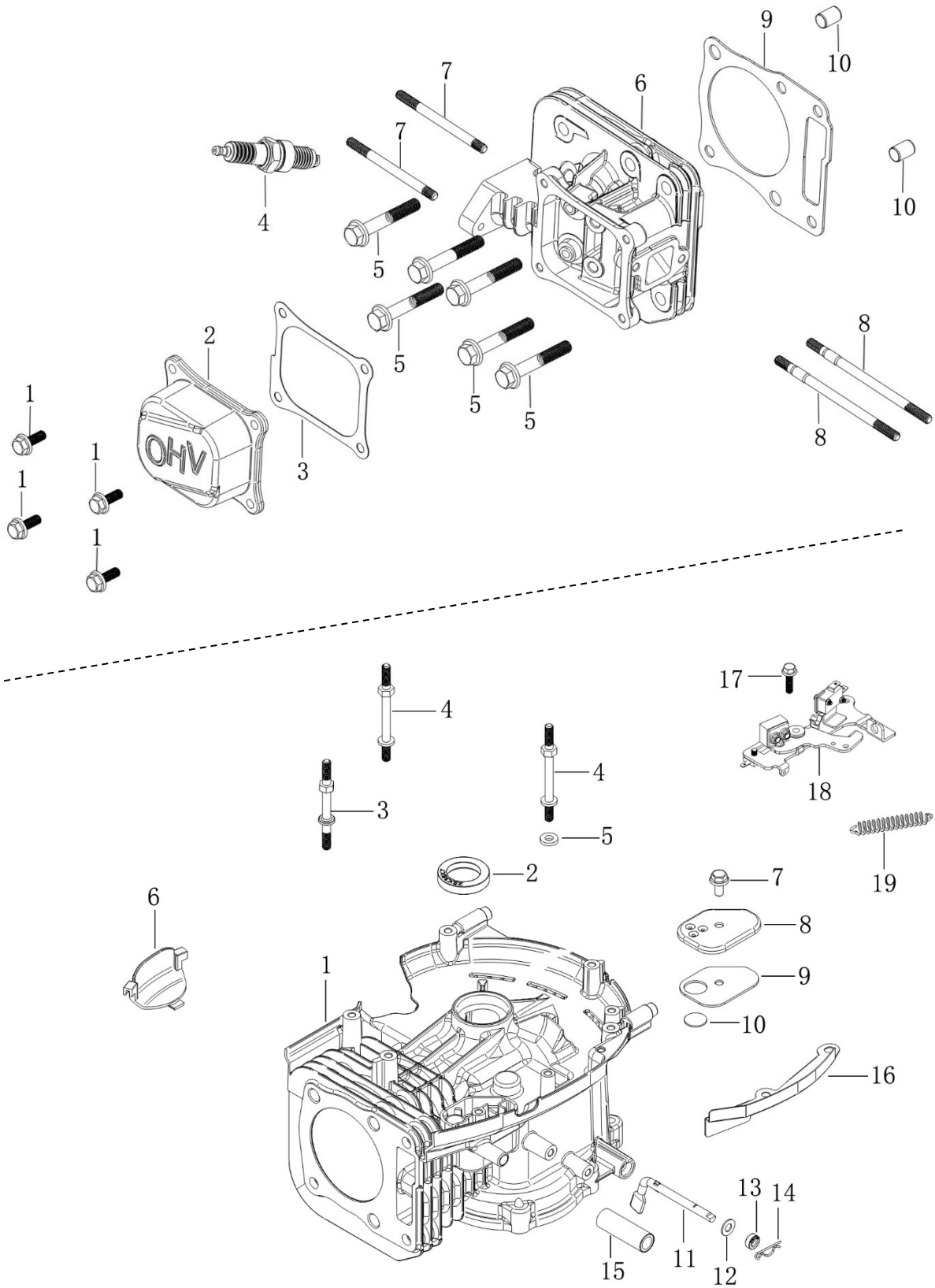

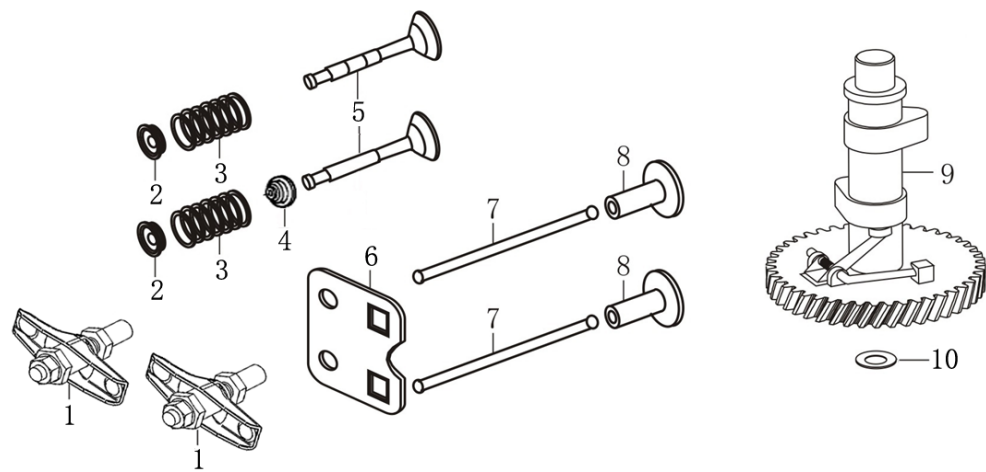
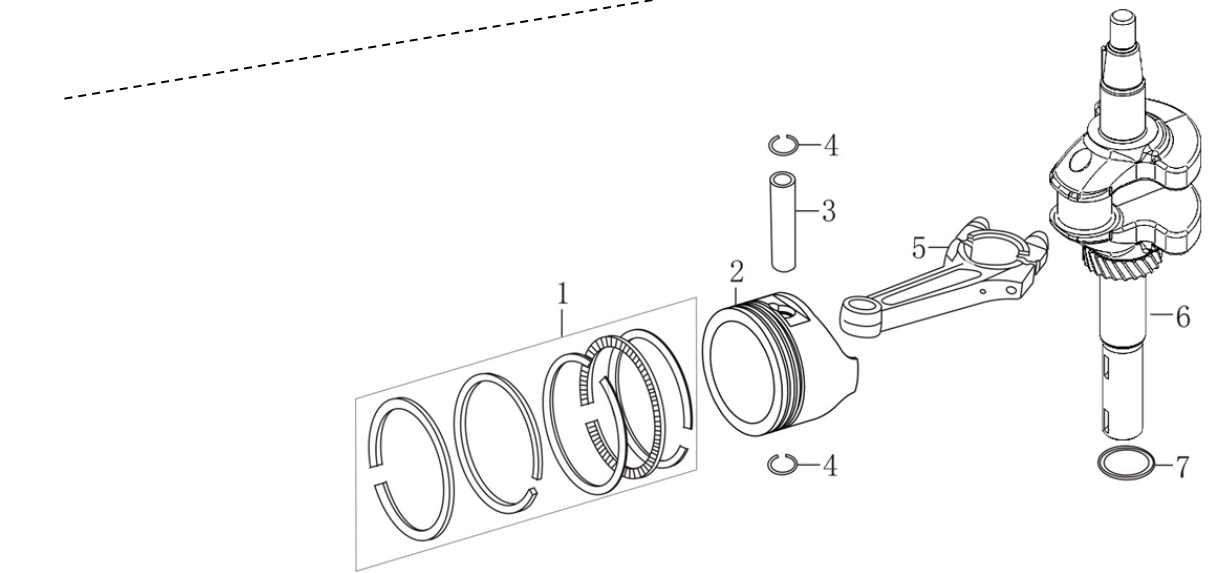
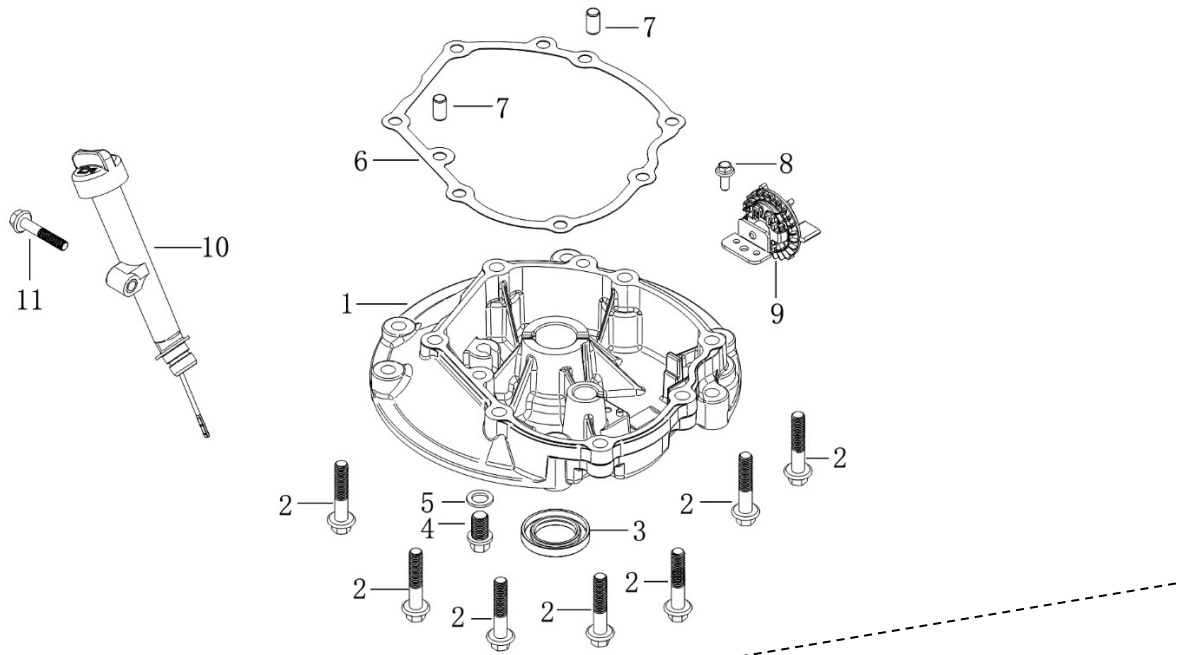

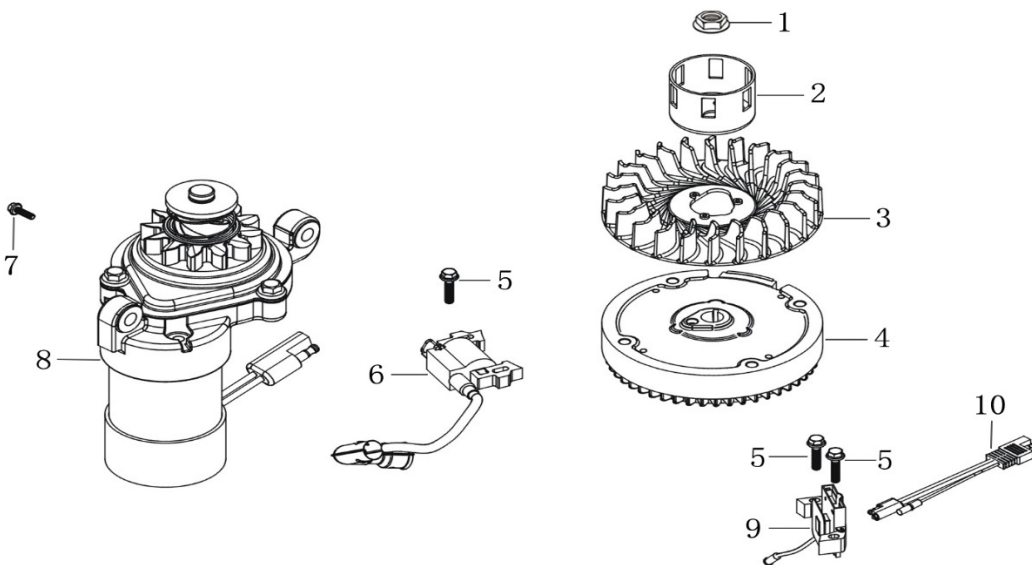
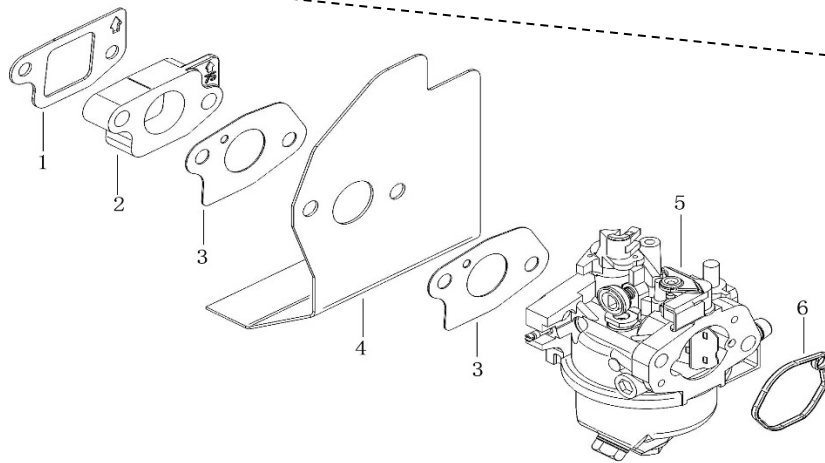
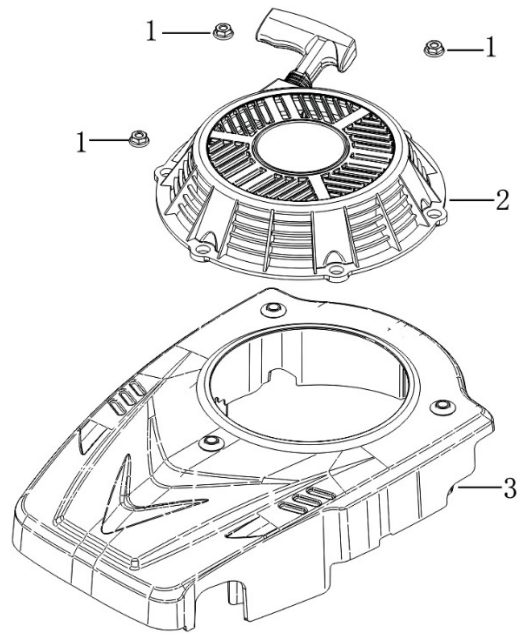

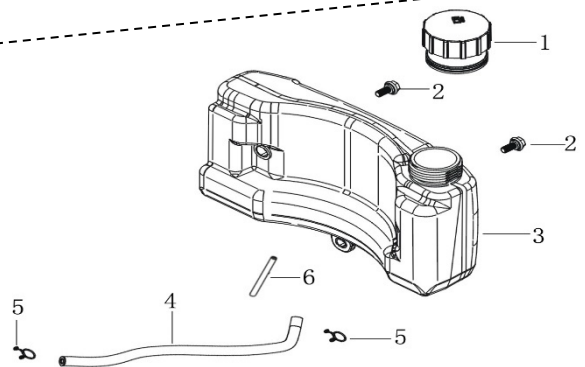
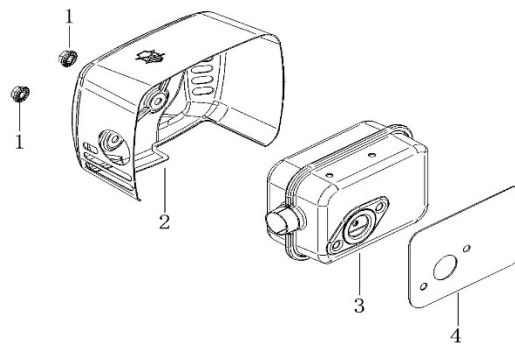
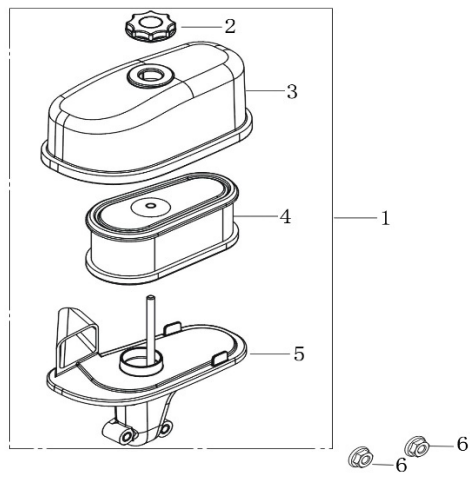
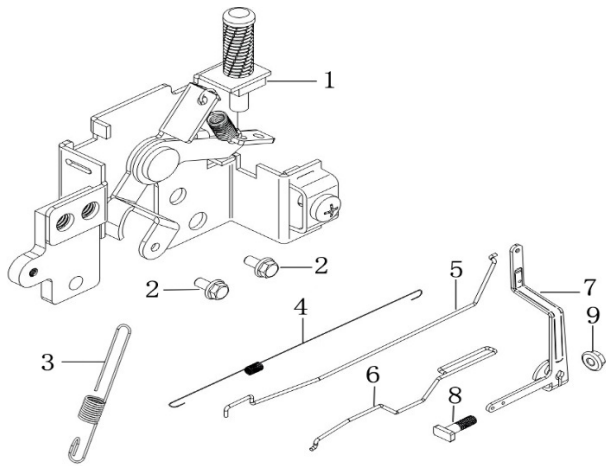

10. CE CERTIFICATE

DISTRIBUTION COMPANY

MILLASUR, SLU

RUA EDUARDO PONDAL, Nº 23 PISIGÜEIRO

15688 OROSO - A CORUÑA

SPAIN



CE DECLARATION OF CONFORMITY

In compliance with the various EC directives, this document confirms that, due to its design and construction, and as indicated by the CE marking affixed by the manufacturer, the machine identified herein meets the relevant and fundamental health and safety requirements of the aforementioned EC directives. This declaration authorizes the product to display the CE marking.

In the event that the machine is modified and this modification is not approved by the manufacturer and communicated to the distributor, this declaration will lose its value and validity.

Machine name: REMOTE CONTROL BRUSH CUTTER

Model: **DCR55**
[RG540]

Recognized and approved standard to which it conforms:

Directive 2006/42/EC (MD)
2014/30/EU (EMC)

Tested according to regulations:

EN ISO 14982:2009
EN ISO 12100:2010
EN ISO 4254-1:2015+A1:2021
EN ISO 4254-12:2012+A1:2017

Company seal

MILLASUR, S.L.U.
Rúa Eduardo Pondal, 23 - Pol. Emp. Sigüeiro
15688-Oroso-A Coruña
Tel. (+34) 981 69 64 65 - Fax (+34) 981 69 08 61
e-mail: millasur@millasur.com
CIF: B-15 749 922

09/02/2026